

Murphymatic® Engine Throttle Controller Model AT03069

The AT03069 is a completely reliable heavy-duty device developed specifically to automatically control engine speed to meet system demand. Low current, high torque, solid-state switching and an electronic clutch make it ideal for all automatic and semiautomatic engine systems. Used with the appropriate Murphy Swichgage® near constant pressure, level and load can be maintained. Speed changes are made slowly and smoothly. The device saves fuel, engine wear, horsepower and labor. One model can be used with both 12- and 24-VDC systems. Check with our engineers for help with other applications where speed control can improve your system.

Applications include:

Pressure

- City water systems
- Water flood injection
- Sprinkler lateral changes
- Make-up if a gang pump stops
- Multiple hose-reel irrigation systems

Level

- Water or oil storage tanks
- Waterflood tanks
- Sewer disposal systems
- Flood control catch basins

Temperature

- Multi-engine cooling systems
- Air conditioned chilled water systems

Engine load

- Empty or fill reservoirs with a lower horsepower engine — fast when head is high — slow when head is low

The AT03069 can enhance features of our Selectronic® Microcontroller units by allowing features such as:

- Warm-up RPM set point
- Minimum RPM set point
- Maximum RPM set point
- Preset operating RPM set point
- Auto throttling to match flows (as needed in flood control applications)
- Maintaining system pressure (as needed in booster station application)
- Adjustable rate of change in RPM (allowing fine tuning of overall system)

For more information, recommendations and quotations contact our engineering department.



IMPORTANT: The AT03069 works on both 12 and 24 VDC systems. System voltage should be between 11 and 28 VDC. Exceeding 28 VDC can cause damage. The automatic throttle controller is used by alternately grounding terminals 2 and 3 to maintain the desired engine RPM. The AT03069 is typically used to automatically adjust the engine speed to maintain a desired discharge pressure on an engine-driven pump.

In order to consistently bring you the highest quality, full-featured products, we reserve the right to change our specifications and designs at any time. MURPHY products and the Murphy logo are registered and/or common law trademarks of Enovation Controls, LLC. This document, including textual matter and illustrations, is copyright protected by Enovation Controls, LLC, with all rights reserved. (c) 2019 Enovation Controls, LLC. A copy of the warranty may be viewed or printed by going to www.enovationcontrols.com/warranty.



Specifications

Voltage: 11-28 VDC negative ground

Maximum Current: 500 mA (1/2 amp)

Standby Current: Approx. 7 mA

Increase and Decrease: Inputs float at approx. 8.4 VDC. Grounding inputs causes 8-18 mA of current to flow from either.

Torque: 25 inch pounds

Sealed limit switches: Factory adjusted, controls maximum travel

Linkage adjustment on lever arm—5 holes: Adjusts travel: 1-3/16 in. (30 mm); 1-11/16 in. (43 mm); 2 in. (51 mm); 2-1/4 in. (57 mm) approximately. Travel Time: 11 to 20 seconds depending on the voltage and force applied.

Net Weight: 5 lb. (2.27 kg)

Operation

A Murphy Swichgage®* constantly monitors pressure, level, temperature or load. Adjustable high and low contacts on Swichgage are set slightly above and below desired operating point. When demand changes, the pointer touches appropriate high or low contact and signals speed change. The AT03069 controller responds only as long as contact is made. The controller stops immediately when contacts separate. Slow, smooth action prevents hunting or surging on normal applications.

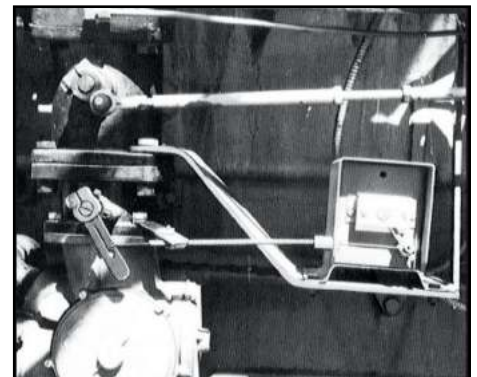

When demand changes, the pointer touches appropriate high or low contact and signals speed change. The AT03069 controller responds only as long as contact is made. The controller stops immediately when contacts separate. Slow, smooth action prevents hunting or surging on normal applications.

*Mercury tube or snap-action switches are not suitable for this type of control. For more information, recommendations and quotations, contact our engineering department.

Dimensions

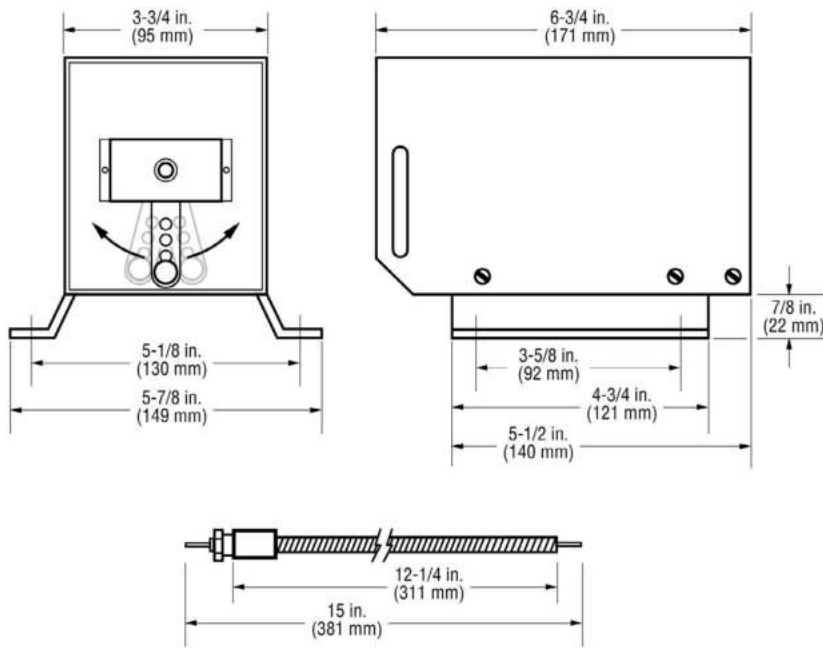

Installation and Wiring

When applying the AT03069, please consider the operating environment. The case is designed to shed water from the top but will collect water if mounted upside down. The control linkage has been specially designed to isolate vibration from the gear motor on the throttle actuator directly to the outer case. This control linkage must be used or vibration may seriously damage the internal gear motor. The flex linkage assembly has been removed for shipping and must be installed before use in the right- or left-hand slots on the sides of the throttle actuator. The AT03069 must be mounted close to, and in line with, the throttle block for straight line pull between the lever arm and the butterfly lever arm.

NOTE: The throttle actuator should be mounted in a manner that minimizes the effects of excessive shock and vibration on the unit.

A separate throttle block must be used if the engine is equipped with a governor or a manual control wire. The AT03069 is not designed to override other controls. The butterfly valve must work freely.

Typical Wiring

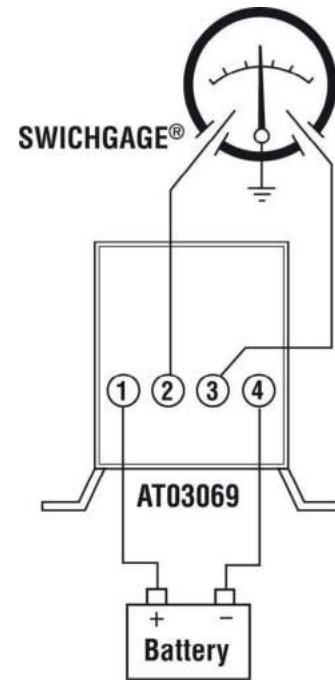

1. Connect terminal #4 to battery (-). Must be connected to a good negative ground. **WARNING:** Damage to the control board will occur if the ground is not connected.
2. Connect terminal #1 to battery (+).
3. Advance the lever arm to the full idle RPM position (fully clockwise or counterclockwise by grounding #2 or #3 (see above diagram)).
4. Connect the flex linkage wire to the butterfly lever arm. Alternately ground terminal #2 and #3 to determine the direction of travel. Select the proper mounting hole in the lever arm of the AT03069 and on the throttle block butterfly arm to provide proper travel. The proper throttler travel is from the mechanical set idle point to just slightly above the point where the mechanical governor limits the engine RPM.
5. Visually inspect the linkage assembly to insure that there are no sharp bends or kinks. If the linkage wire bows during operation, a center support should be added.
6. After correct travel is established, tighten the set screws and linkage assembly.

NOTE: The lever arm must be allowed to travel its full arc. This allows the unit to disconnect itself with internal limit switches. If the lever is unable to reach limit switches, damage to the unit can occur.

Warranty - A limited warranty on materials and workmanship is given with this Murphy product. A copy of the warranty may be viewed or printed by going to www.enovationcontrols.com/warranty

SALES CONTACT

ENOVATION
CONTROLS[®]

CONTACT

✉ sales@rajkotmarinellc.ae
☎ +971 6 7487580
🌐 www.rajkotmarine.com

RAJKOT MARINE LLC

Jerf Industrial Area 1,
P.O Box 5861
Ajman, UAE

