

# 4.5" (114 mm) Dial Temperature Gage SPL Series

The 4-1/2" (114 mm) size dial gage is a mechanical gage for temperature indication. It is a combination indicating gage and critical temperature limit switches. High and low temperature limit contacts are visible. It includes adjustable, electrical contacts that can be used for start and stop, to trip alarms and to shut down equipment.

Panel and wall-mount versions are available as well as latching control relay versions.

Ranges are available from 15° to 250° F (9° to 121° C) through 130° to 350° F (54° to 177° C).

Typical applications include:

- Gas compressors • Engine coolant temperature
- Heaters and coolers • Process temperature
- Water pump temperature

## Basic Models

SPLC Series gage: Surface-mount version of the gage.

For these models the gage pointer makes with two adjustable contacts to complete a pilot-duty circuit.

SPLFC Series gage: Panel-mounting (round case) version of the SPLC.

FW Murphy offers square case configurations altered to fit round panel openings, see Dimensions.

## Specifications

**Dial:** White on black, dual scale, ° F and ° C standard, 4-1/2 in. (114 mm) diameter

**Case:** Die-cast aluminum, surface or panel mount

**Capillary:** PVC-armored copper tube, 5 ft. long (1.5 m) standard – see options

**Sensing Bulb:** Copper bulb: 1/2 in. (13 mm) OD  
Length: 7 in. (178 mm)

Minimum bulb insertion – see corresponding chart

Pressure Rating: 600 psi (4.1 MPa) [41 bar]. Connection: 1/2 NPT compression fitting

**Overrange:** Do not exceed 10% above full range

**Limit Contacts (SPLC & SPLFC):** 1-SPDT, Center off; pilot-duty; 2 A @ 30 V / 0.1 A @ 125 VAC. Contacts are gold-plated silver.

**Dry Relay Contact (BP Models):**

10 A @ 28 VDC or 10 A @ 120 VAC

**Wire Connections:**

Surface-mount models: 1/2 NPT conduit and terminal block

Panel mount models: Wire leads, 18 AWG (1.0 mm<sup>2</sup>) x 9 in. (229 mm) long

OS models: 1/2 NPT conduit and wire leads,

18 AWG (1.0 mm<sup>2</sup>) x 9 in. (229 mm) long

**Item Weight:** 8 lb. (3.6 kg) approximately; Explosion-proof models: 22 lb. (10 kg) approx.

**Item Dimensions:** 16 x 11 x 5-1/2 in. (406 x 279 x 140 mm);

Explosion-proof models: 12 x 12 x 9 in. (305 x 305 x 229 mm)



1 Products covered by this bulletin comply with EMC Council directive 89/336/EEC regarding electromagnetic compatibility except as noted.

2 Selected configurations are third-party listed. Call FW Murphy for details.

## Basic Operation

This vapor-actuated gage features a sealed capillary tube and sensing bulb. When subjected to heat, the liquid in the sensing bulb expands to vapor creating pressure against a bourdon tube mechanism. The bourdon tube translates this vapor pressure into a mechanical gage reading.

For models SPLC and SPLFC, the gage pointer acts as a pressure indicator and as one switch pole, which completes a circuit when it touches the adjustable limit contacts. Contacts have self-cleaning motion to ensure electrical continuity. A toggle switch is provided on SPLC models to override the low contact for equipment start-up.

## Dimensions

### Surface-Mount Models

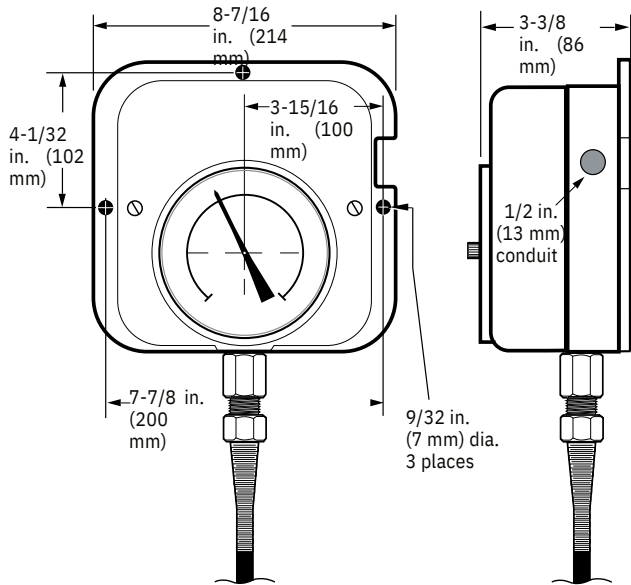

Surface-mount models SPLCE and SPLBE feature square case but altered to standard round panel mounting - not pictured.

### Panel-Mount Models

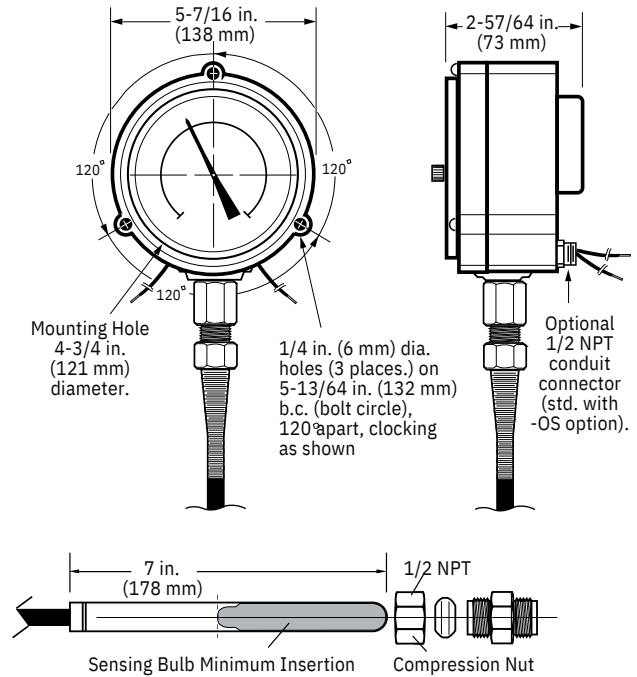

## Ranges and Accuracy – Sensing Bulb Insertion

Temperature Ranges Available (dual scale dials)		Accuracy (SPL Models)			Minimum Sensing Bulb Insertion into Process
Fahrenheit	Celsius	First 1/3	Middle 1/3	Upper 1/3	
15° to 250°	9° to 121°	±8°F/±4°C	±2°F/±1°C	±2°F/±1°C	5 in. (127 mm)
130° to 350°	54° to 177°	±8°F/±4°C	±2°F/±1°C	±3°F/±1.5°C	2-1/2 in. (64 mm)

## Using a Thermowell

Installing a thermowell is recommended for high pressure applications or corrosive environments. It also allows sensing bulbs to be changed or adjusted without opening the connection to process. FW Murphy offers thermowells, see How to Order.

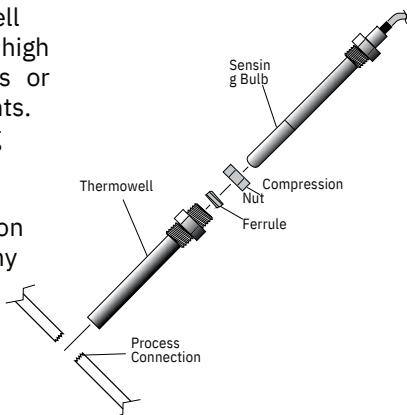

## Start-Up Lockout

The SPLC gage low limit contact can be bypassed for equipment start up. A toggle switch is provided for this purpose. The toggle switch must be manually reset when temperature rises above the low limit.

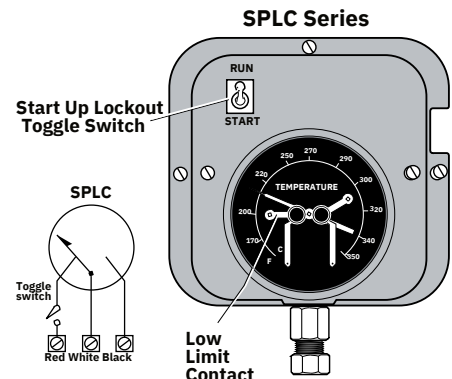

## How the SPL Works

SPLC and SPLFC gage temperature indicator gages include two pilot-duty, pointer-type limit contacts (one for high and one for low) that can be used for alarm and/or shutdown. The SPLC and SPLFC models will complete a circuit when the gage pointer and either limit contact meet. This provides an electrical signal to alert the operator of critical temperature conditions or when required, to shut down the equipment. Both limit contacts (high and low) are field adjustable by simply turning the fingertip-type knob to the desired point on the scale dial. This graphic shows details of a typical SPLFC gage model.

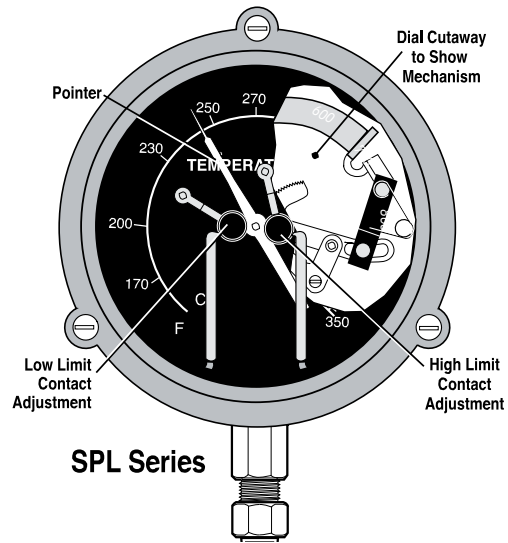

## How to Order

Options listed below. All configurations may not be available. Call your sales representative or FW Murphy for more information.

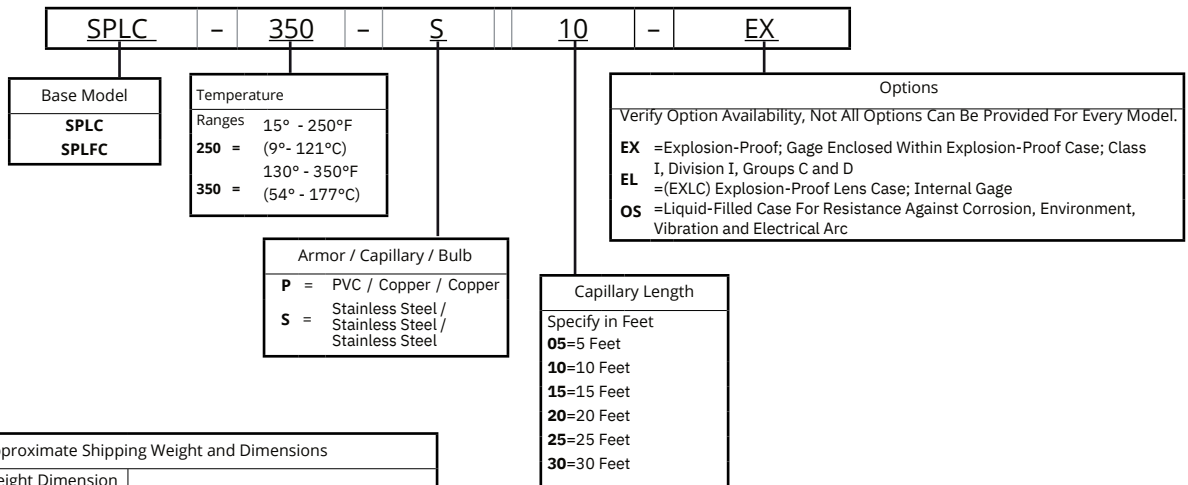

Approximate Shipping Weight and Dimensions		
Model	Weight	Dimension
SPLC	8 lb. (3.6 kg)	16 x 11 x 5-1/2 in. (406 x 279 x 140 mm)
Explosion Proof	22 lb. (10 kg)	12 x 12 x 9 in. (305 x 305 x 229 mm)

Part Number	Model and Description	Notes
05000610	Tamper-proof Contact Accessory	<p>The image shows two cylindrical limit switch knobs with electrical leads. A red arrow points to a 'Knob Lock' mechanism on the right knob. Another red arrow points to the 'Limit Switch Knobs' themselves.</p>

Continued on next page.

# How to Order (continued)

Part Number	Model and Description	Notes
10000582	<p>Thermowell used with SPLC                      Rated 3000 psi @ 300o F (20.7 MPa @ 149o                      C) Material is 304 Stainless Steel                      Furnished with compression nut and ferrule</p> <p>A. 6.375 in. (162 mm) E. 0.660 in. (17 mm)                      B. 6.050 in. (154 mm) F. 1/2-14 NPT                      C. 4.536 in. (115 mm) G. 0.875 Hex                      D. 0.510 in. (13 mm) H. 11/16-20 UN-2A</p>	
10000583	<p>Thermowell used with SPLC                      Rated 3000 psi @ 300o F (20.7 MPa @ 149o                      C) Material is 304 Stainless Steel                      Furnished with compression nut and ferrule</p> <p>A. 5.000 in. (127 mm) E. 0.660 in. (17 mm)                      B. 4.680 in. (119 mm) F. 1/2-14 NPT                      C. 3.160 in. (80 mm) G. 0.875 Hex                      D. 0.510 in. (13 mm) H. 11/16-20 UN-2A</p>	
10000584	<p>Thermowell used with SPLC                      Rated 4000 psi @ 300o F (27.6 MPa @ 149o                      C) Material is 304 Stainless Steel                      Furnished with compression nut and ferrule</p> <p>A. 6.375 in. (162 mm) E. 0.810 in. (21 mm)                      B. 6.050 in. (154 mm) F. 3/4-14 NPT                      C. 4.524 in. (115 mm) G. 1.125 Hex                      D. 0.510 in. (13 mm) H. 11/16-20 UN-2A</p>	
10000585	<p>Thermowell used with SPLC                      Rated 4000 psi @ 300o F (27.6 MPa @ 149o                      C) Material is 304 Stainless Steel                      Furnished with compression nut and ferrule</p> <p>A. 5.000 in. (127 mm) E. 0.810 in. (21 mm)                      B. 4.680 in. (119 mm) F. 3/4-14 NPT                      C. 3.150 in. (80 mm) G. 1.125 Hex                      D. 0.510 in. (13 mm) H. 11/16-20 UN-2A</p>	
10000668	<p>Thermowell used with SPLC                      Rated 3000 psi @ 300o F (20.7 MPa @ 149o                      C) Material is 316 Stainless Steel                      Furnished with compression nut and ferrule</p> <p>A. 5.000 in. (127 mm) E. 0.660 in. (17 mm)                      B. 4.680 in. (119 mm) F. 1/2-14 NPT                      C. 3.160 in. (80 mm) G. 0.875 Hex                      D. 0.510 in. (13 mm) H. 11/16-20 UN-2A</p>	



### CONTACT

✉ sales@rajkotmarine.ae  
 ☎ +971 6 7487580  
 🌐 www.rajkotmarine.com

### RAJKOT MARINE LLC

Jerf Industrial Area 1,  
 P.O Box 5861  
 Ajman, UAE

