

Liquid Level Switches

LS200 Series

Designed for harsh gas compressor scrubber applications, the LS200 Series Liquid Level Switches feature a robust design that trips on rising liquid level only. With both electric and pneumatic models available, the instruments screw directly into the vessel or can be mounted via an external float chamber. The nickel-plated body provides enhanced corrosion protection while the 304 stainless steel float operates in 0.55 specific gravity and heavier fluids. Additional features include:

- Rated for 2000 psi (13.8 MPa) [138 bar] working pressure
- Listed for cCSAus Class I, Div 1, Grps C & D locations
- Canadian registered
- Stainless steel models available for corrosive atmospheres

The LS200 Series replaces the FW Murphy Series L1200 Liquid Level Switches. The MSLS (Scrubber Level System) replaces the LS200 high-level shut-down switch with the MLS-020 magnetic level switch.

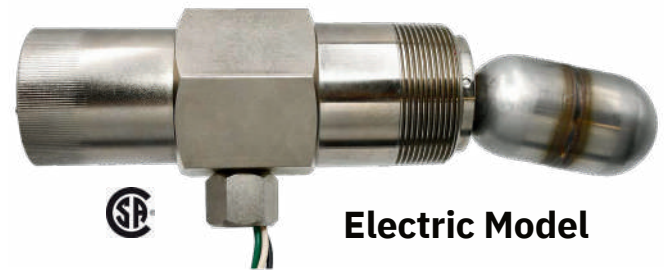

Electric Model



Pneumatic Model

Models

LS200 Liquid Level Switches with 2 in. NPT mounting are float activated to operate an electrical SPDT snap-switch (optional DPDT on some models) for alarm or shutdown of an engine or electric motor. The LS200 connects directly into the vessel wall and can be used with an FW Murphy weld collar or FW Murphy external float chamber.

LS200NDVOR is a float-activated, pneumatic-vent level device used to operate DVU Series dump valves or similar devices. It provides a 2 in. NPT mounting with a pneumatic output for interfacing with pneumatic devices such as the FW Murphy pneumatic dump valve or other pneumatic instrumentation.

LS200NDVO is the Dump Valve Operator (DVO) without the pressure regulator for those applications where the system provides a filter regulator for instrument-quality air or gas as the control medium.

LS200N is the pneumatic level switch without the DVO or filter regulator. Please note: pneumatic media devices require clean, dry, instrument-quality air or gas.

Dimensions

LS200, L1100

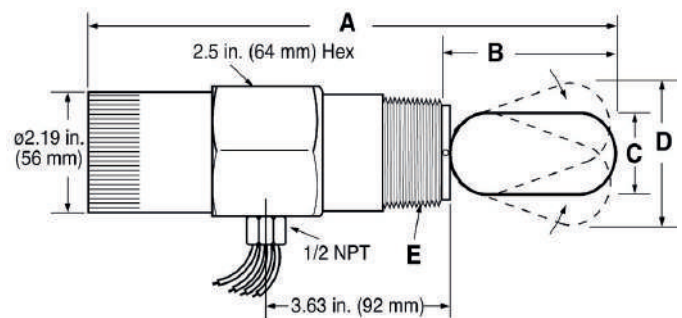

	LS200	L1100*
A	10.16 in (258	11 in. (279 mm)
B	mm) 3.44 in. (87	3.50 in. (189 mm)
C	mm) 1.75 in. (44	1.56 in. (40 mm)
D	mm) 2.80 in. (71	3.4 in. (71 mm)
E	mm)	1-1/2 NPT

*The L1100 has been discontinued and remains in the table for reference purposes only.

Application Data

Pipe Data				
Nom. Size (inches)	O.D. (inches)	Schedule Number	Wall Thickness (inches)	Inside Diameter (inches)
3	3.5	40ST	0.216	3.068
3	3.5	80XS	0.3	2.9
4	4.5	40ST	0.237	4.026
4	4.5	80XS	0.337	3.826

Minimum Clearance with Full Thread Engagement				
Product	Insertion Depth (inches)		Vertical Clearance (inches)	
	Std.	w/ 1" Extension	Std.	w/ 1" Extension
LS200	4.6	5.6	2.8	3.15
LS200N	5.43	6.4	3.3	3.9
L1200	4.65	5.7	3.9	4.55
L1200N	5.6	6.7	5.3	6.9
L1100	4.4	5.4	3.4	4.05

Models L1200, L1200N and L1100 are discontinued and remain in the table for reference purposes only.

LS200N, LS200NDVO and LS200NDVOR with Dump Valve Operator, Pressure Regulator and Gage

CAUTION:

LS200 Series parts are not interchangeable with the L1200 Series.

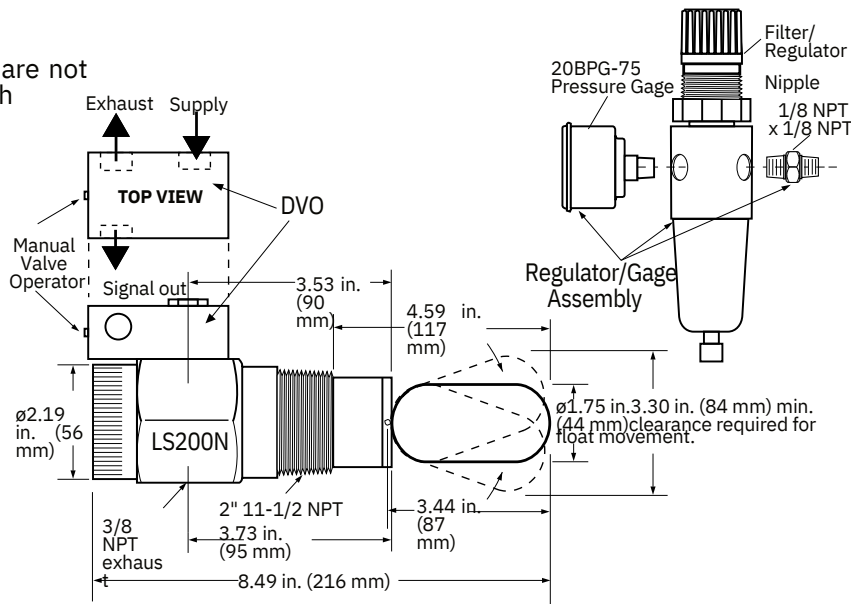

Accessories

Refer to LS200 installation and operation manual for additional information.

External Float Chamber

Operating Pressure: 2000 psi (13.8 MPa) [138 bar]
Operating Temperature: 400° F (204° C)

Weld Collar

Operating Pressure: 2000 psi (13.8 MPa) [138 bar]
Operating Temperature: 400° F (204° C)

Float Shaft Extension

LS200 Series: 1 in.

LS200 Minimum Allowable Specific Gravity			
Model	Float Extension Length (inches)	Pressure (psi)	Specific Gravity
LS200	0	2000	0.55
	1		0.7
LS200NDVO	0	2000	0.63
	1		0.73

Specifications

All Models

Listed for cCSAus Class 1, Div 1, Grps C & D Locations
Canadian Registration Numbers (issued by ABSA):
 LS200: 0F01476.2
 L1200, L1200N and L1100 Series: 0F01476.0
Body: Nickel-plated; optional 316 stainless steel
Float: 304 stainless steel
Pressure Rating: 2000psig (13.8 MPa) [138 bar]

LS200

O-ring: Viton
Process Connection: 2" NPT
Temperature Rating: -20° to 300°F (-29° to 149°C)
Electrical: SPDT std.
Wiring: 18 AWG x 36 in. (1.0 mm² x 916 mm)

LS200NDVOR

Process Connection: 2" NPT
DVO Valve: 3-way N.C. w/manual operator, all connections 1/8" NPT (minimum 30 psig required)
Filter/Pressure Regulator Set:
Regulator: 0 to 75 psig (0 to 517 kPa) [0 to 5.17 bar] range
Maximum Input Pressure: 300 psig (2.07 MPa) [20.7 bar]

LS200NDVO

Process Connection: 2" NPT
DVO Valve: 3-way N.C. w/manual operator, all connections 1/8" NPT
LS200N
Process Connection: 2" NPT
Vent Valve: 2-way N.C. w/ 1/16 in. (2 mm) orifice and Viton seat; Inlet: 1/8" NPT; Outlet: 3/8" NPT

Electrical

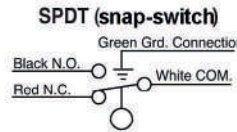

Switch Rating: 5 A @ 125-250- 480 VAC
 1/2 A @ 125 VDC
 1/4 A @ 250 VDC
 2A @ 6-30 VDC Resistive
 1A @ 6-30 VDC Inductive

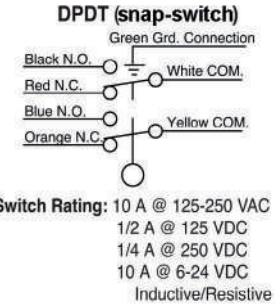

Switch Rating: 10 A @ 125-250 VAC
 1/2 A @ 125 VDC
 1/4 A @ 250 VDC
 10 A @ 6-24 VDC Inductive/Resistive

How to Order

Options listed below. All configurations may not be available. Call your sales representative or FW Murphy for more information.

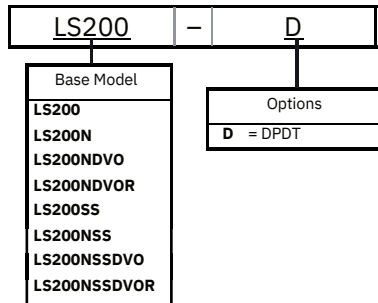

Approximate Shipping Weight and Dimensions		
Model	Weight	Dimension
LS200	6 lb. 12 oz.	13-1/2 x 4-1/2 x 3-1/2
LS200SS	6 lb. 13 oz.	in. 13-1/2 x 4-1/2 x 3-
LS200N	5 lb. 1 oz.	1/2 in. 13-1/2 x 4-1/2 x
LS200NDVO	5 lb. 15 oz.	3-1/2 in. 13-1/2 x 4-1/2
LS200NDVOR	6 lb. 8 oz.	x 3-1/2 in. 13-1/2 x 4-
		1/2 x 3-1/2 in.

Part Number	Description	Notes
15700799	External Float Chamber	
15050375	Weld Collar	Shipping Weight: 6 lb. (2.7 kg)
15000478	1 in. Float Shaft Extension	LS200 Series
15010216	Dump Valve Operator Assembly	DVO, new style

Note: Refer to the Installation and Operation manual 00-02-0671 for replacement parts at fwmurphy.com.



CONTACT

✉ sales@rajkotmarinellc.ae
 ☎ +971 6 7487580
 🌐 www.rajkotmarine.com

RAJKOT MARINE LLC

Jerf Industrial Area 1,
 P.O Box 5861
 Ajman, UAE

