



CONTACT

✉ sales@rajkotmarinellc.ae

☎ +971 6 7487580

🌐 www.rajkotmarine.com

RAJKOT MARINE LLC

Jerf Industrial Area 1,

P.O Box 5861

Ajman, UAE

MURPHY®

by **ENOVATION** CONTROLS



PowerView® Model PV450

Installation and Operation Manual

00-02-0732
2016-02-26
Section 78

In order to consistently bring you the highest quality, full featured products, we reserve the right to change our specifications and designs at any time. The latest version of this manual can be found at www.fwmurphy.com.

Warranty - A limited warranty on materials and workmanship is given with this Murphy product.
A copy of the warranty may be viewed or printed by going to www.fwmurphy.com/warranty.



BEFORE BEGINNING INSTALLATION OF THIS MURPHY PRODUCT:

- Read and follow all installation instructions.
- Please contact Enovation Controls immediately if you have any questions.
- A visual inspection of this product for damage during shipping is recommended before installation.
- It is your responsibility to ensure that qualified mechanical and electrical technicians install this product.

Contact Enovation Controls Technical Service if you have any questions or concerns at: +1 918-317-4100.

Table of Contents

Hardware Installation	1
Inspecting Package Contents	1
Dash-Mounted Installation	1
Wiring Instructions	4
Single Engine	4
PVA Gages	5
NMEA Gages	6
Dual Engine Gages	7
USB Wiring	8
Analog Video	9
No Video Wiring	10
Pin Specifications for Deutsch DT04-6P Style Connections	11
PV450 Features and Operations	12
Setting Up your PV450 Display for the First Time	13
Product Features	15
Power Up	15
Main Menu	15
Gauge Display	16
Engine Diagnostics	18
Fault Code Popups	19
User Settings	20
Utilities	24
Specifications	26
Addendum	27
How to Install a Configuration from a USB Drive for the PV450	27

Hardware Installation

The following instructions will guide you through installing the PV450 display.

Inspecting Package Contents

~~Before attempting to install the product, it is recommended that you ensure all parts are~~ accounted for and inspect each item for damage (which sometimes occurs during shipping). The items included in the box are:

Installation kit – P/N 78-00-0782 includes:

- 4 ea. machine screws and flat washers
- 4 Nylock nuts
- 1 small bag

Dash-Mounted Installation

Tools needed.

- Drill with 5/32" size bit
- Jig Saw or tool that cleanly cuts through dash material.
- Wrench or socket

Preparing the Dash

Determine the location of the PowerView 450 in the dash. Use the Installation Template (included at the end of the manual) as a guideline to cut a hole in the dash to the specified dimensions. Drill holes where indicated on the template for the mounting screws.

NOTE: When using the paper template from the manual, please be aware that if you downloaded this document from the FW Murphy website, the pdf file may not automatically print to scale. When submitting the file for print, you will need to select "None" for Page Scaling. Check the accuracy of the printed template by verifying the measurements labeled on the template are correct.
If this manual was supplied with your product, the template will be correct.

Front Installation of Display

1. Place the back side of the display through the opening in the dash.
2. Use the 4 screws to line up the unit with the drilled holes.
3. Push the unit through the opening and screws through the drilled holes until the back of the case is flush.
4. Use the Nylock nuts provided to tighten unit to the dash. Use the appropriate wrench or socket to tighten. Torque lock nuts to 8-10 inch pounds.

Back Installation of Display

1. Cut the dash to allow for the display. Ensure the materials are available to properly secure the unit within the dash. Torque the 6-32 Nylock nuts to 5 inch pounds.
2. Place the display behind dash and line up the four mounting holes on the display with the holes in dash.
3. Install four bolts and tighten nuts.

Gimbal Mounted Installation

If it is desired to gimbal-mount the PV450, the gimbals can be sourced from Ram Mounting Systems, Inc. at www.ram-mount.com

The RAM parts, drawings and models are accompanied by a ordering guide at <http://www.rammount.com/SupportCenter/GlossaryofTerms/tabid/149/Default.aspx>

The PV450 has a matching bolt pattern for the RAM Diamond base with 9/16" ball (P/N RAM-A-238).

Dimensions for Installation

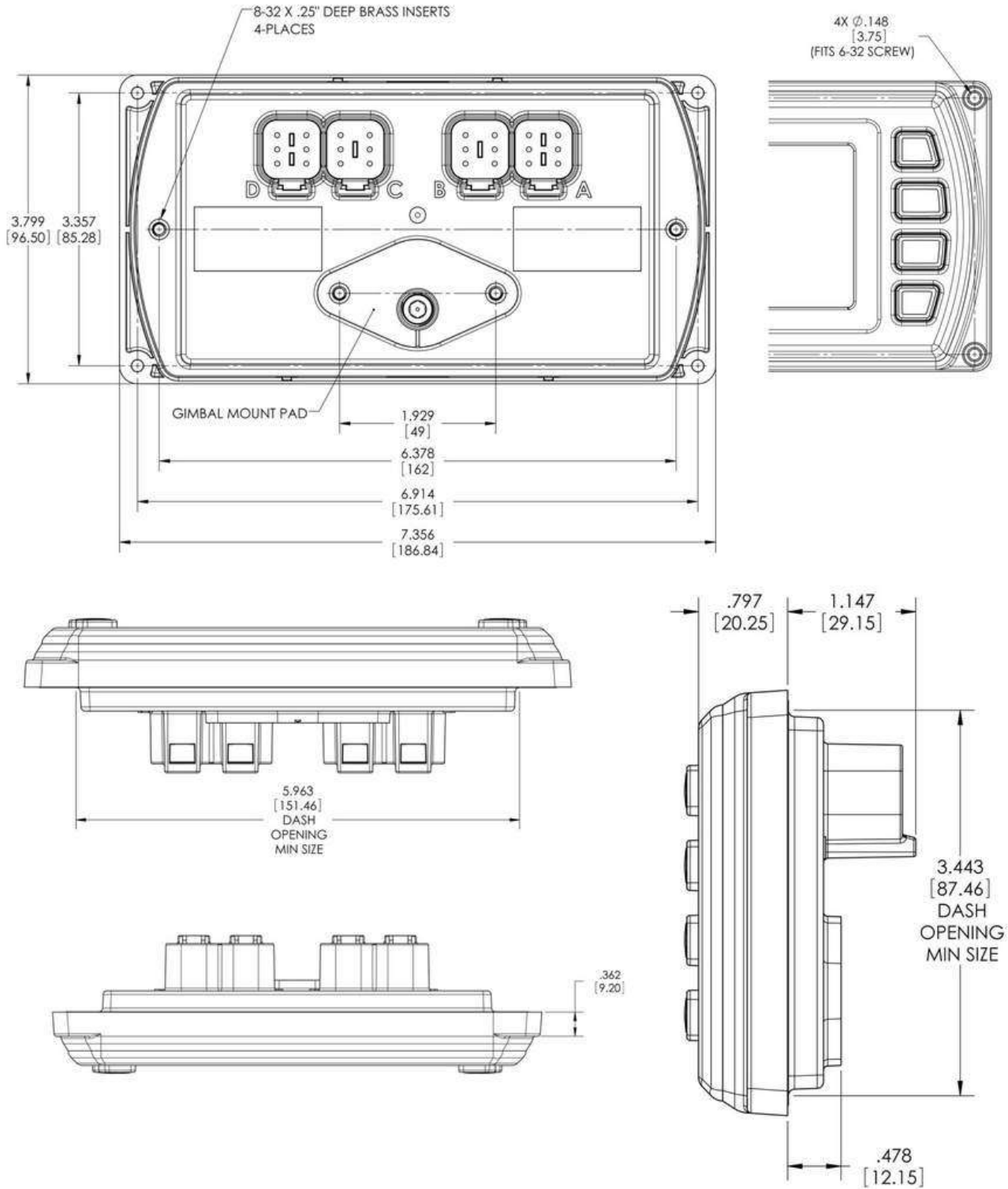

Wiring Instructions

The following illustrations are examples of various typical quick-connect options for setup. Wiring harnesses are sold separately.



WARNING: Failure to install the unit per the specified wiring diagrams may cause damage to the unit. **DO NOT** connect power to the video ground. Warranty is void for damage caused by incorrect wiring.

Single Engine

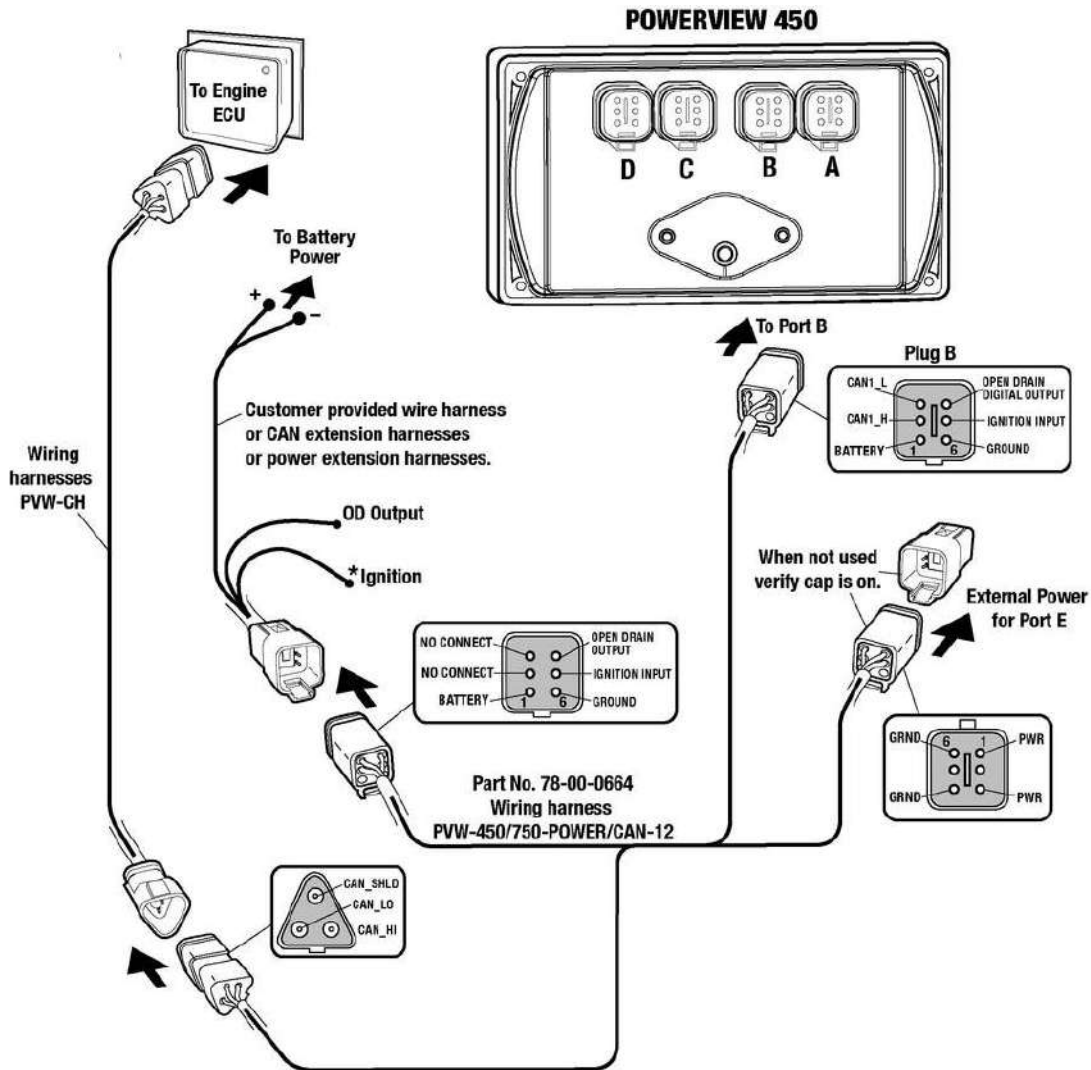

* Note: Ignition must be connected to the battery or to an ignition switch for the display to turn "ON".

PVA Gages

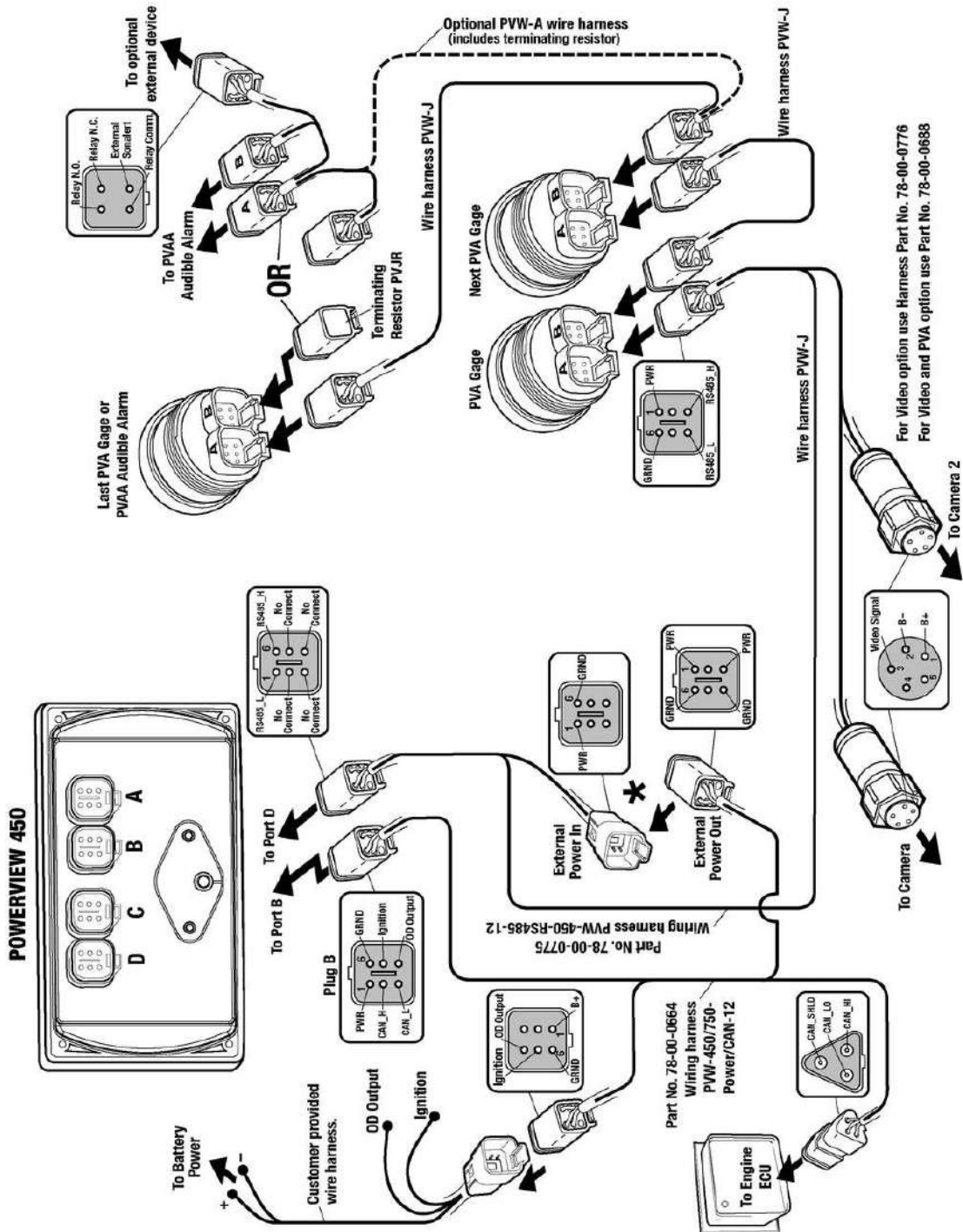

WARNING: Failure to install the unit per the specified wiring diagrams may cause damage to the unit. **DO NOT** connect power to the video ground. Warranty is void for damage caused by incorrect wiring.

NMEA Gages

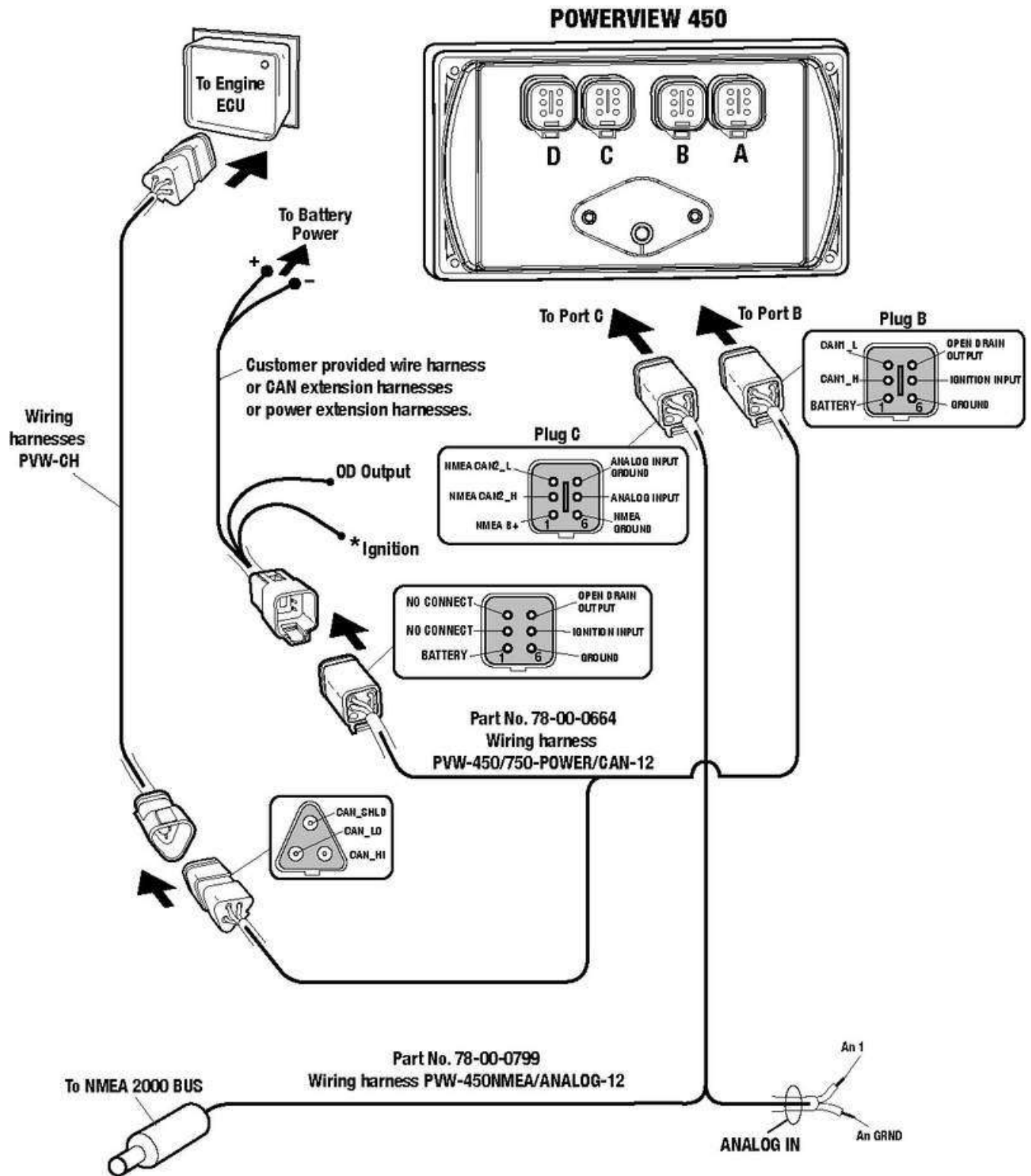

Dual Engine Gages

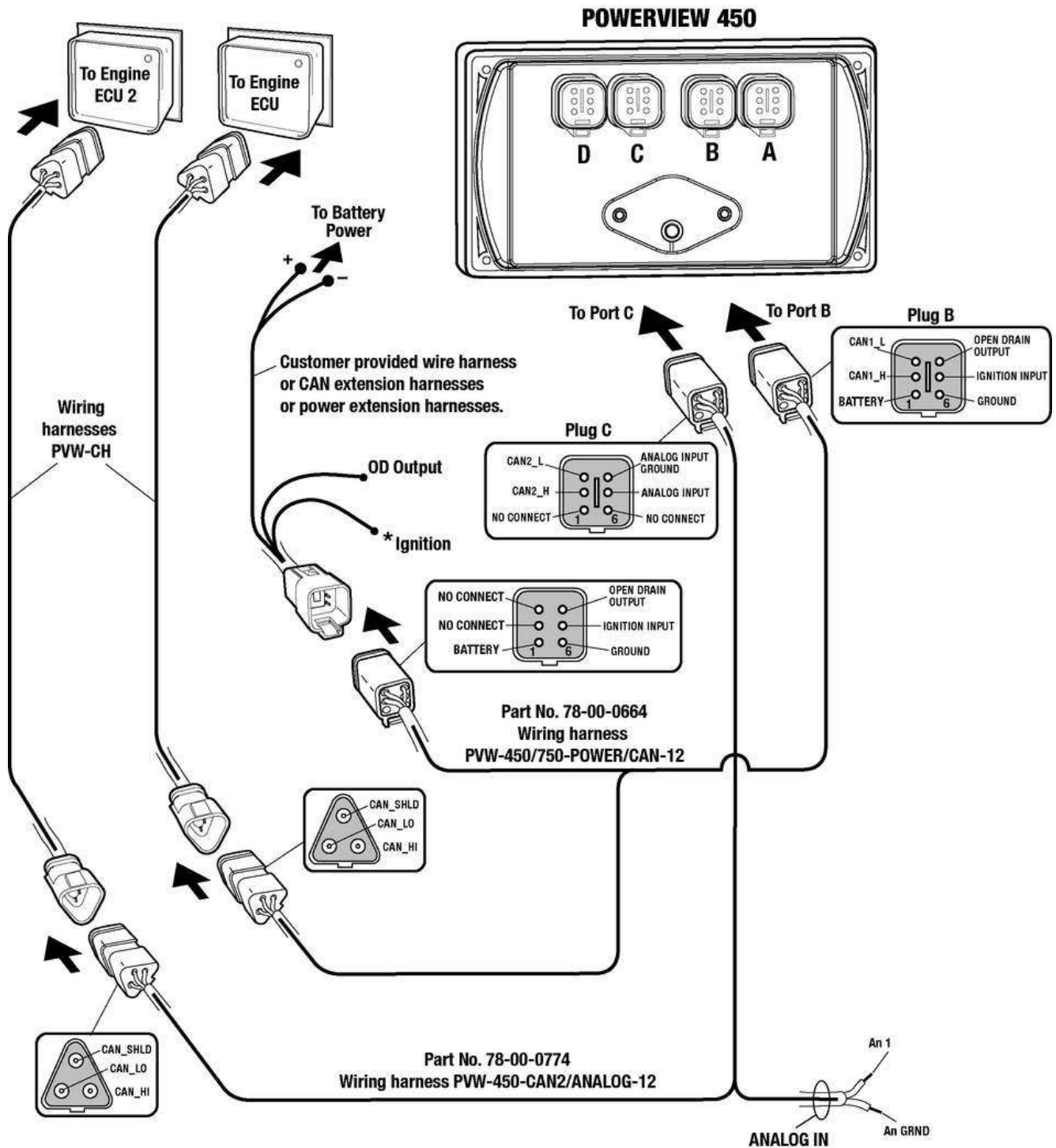

NOTE: Port B and C connectors are keyed differently than Port A and D connectors to ensure proper connection.

USB Wiring

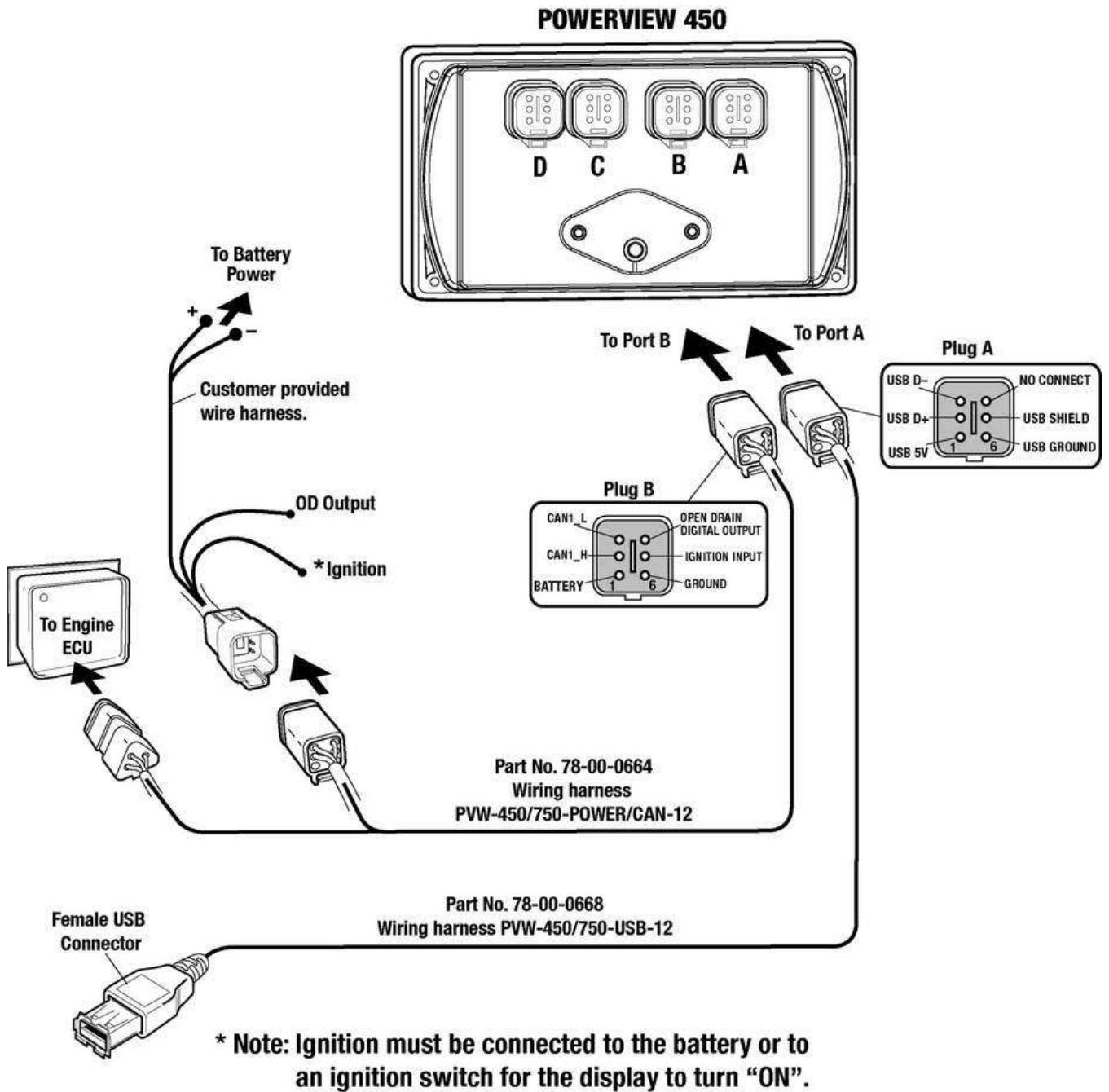

Analog Video

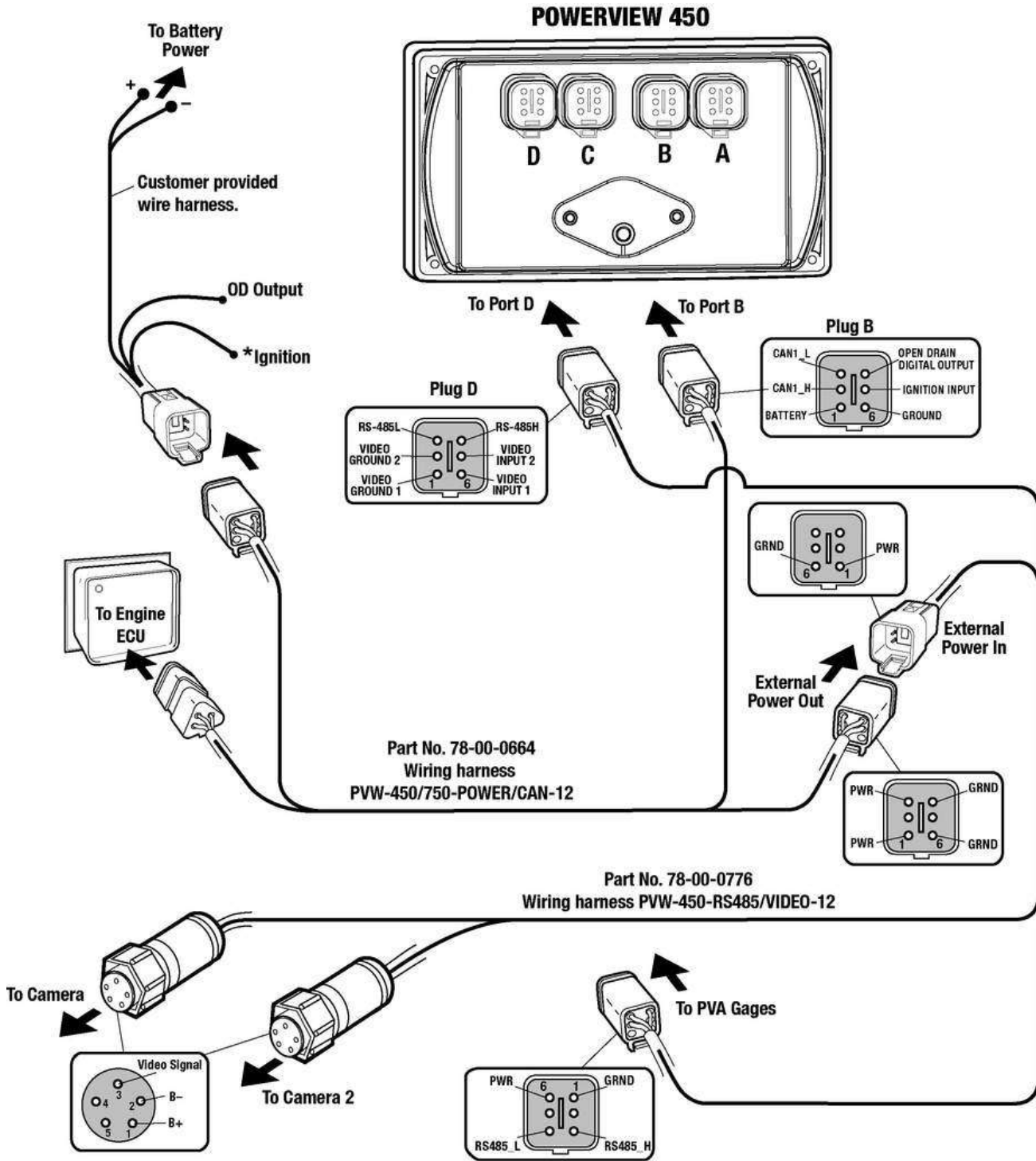

WARNING: Failure to install the unit per the specified wiring diagrams may cause damage to the unit. **DO NOT** connect power to the video ground. Warranty is void for damage caused by incorrect wiring.

No Video Wiring

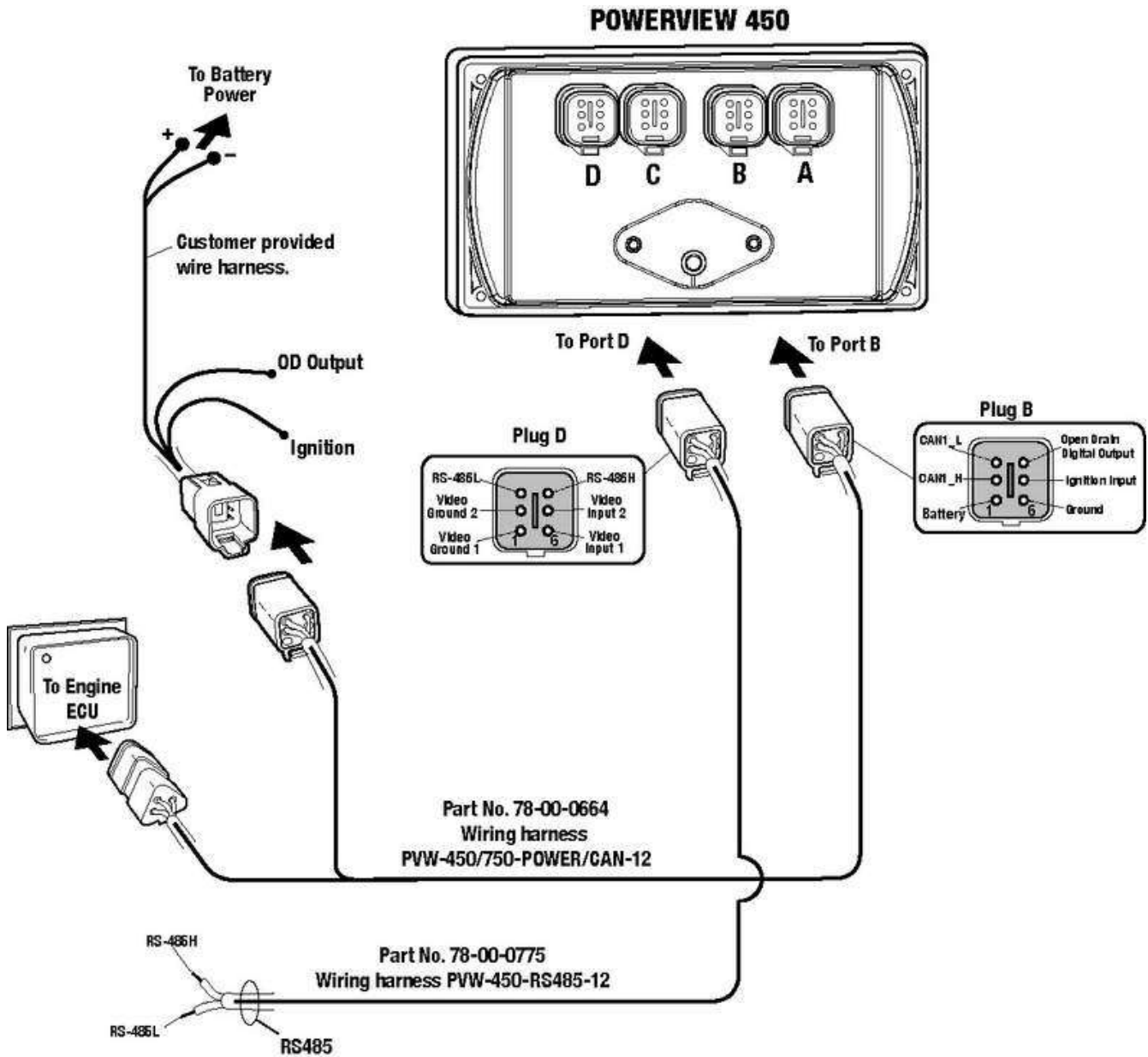

WARNING: Failure to install the unit per the specified wiring diagrams may cause damage to the unit. **DO NOT** connect power to the video ground. Warranty is void for damage caused by incorrect wiring.

Pin Specifications for Deutsch DT04-6P Style Connections

POWerview 450 BACKVIEW

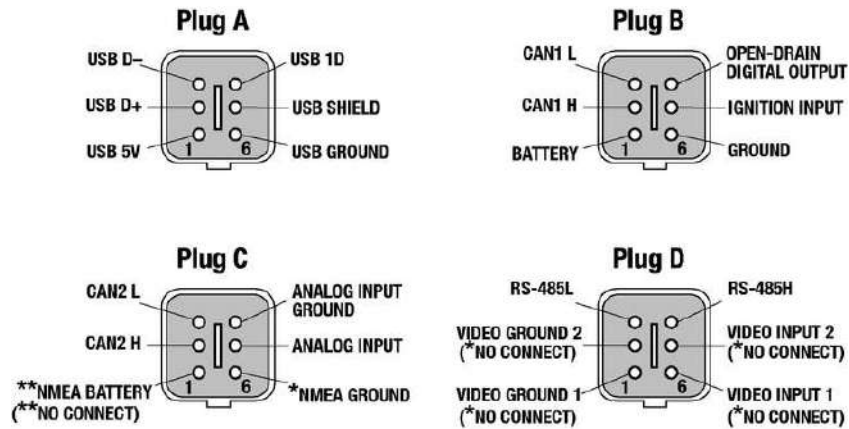
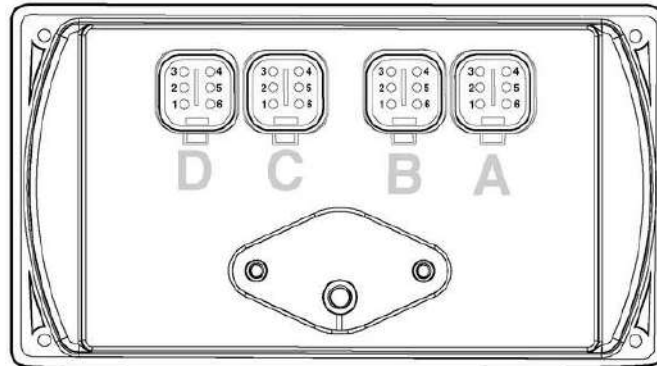

* (PIN NOT CONNECTED ON VERSION WITHOUT VIDEO).
 ** (PIN NOT CONNECTED ON VERSION WITHOUT NMEA 2000).



WARNING: Failure to install the unit per the specified wiring diagrams may cause damage to the unit. **DO NOT** connect power to the video ground. Warranty is void for damage caused by incorrect wiring.

Signal Definitions

- CAN: 2.0A and 2.0B
- 1 port isolated according to NMEA 2000 (optional)
- USB 2.0, Video input (optional): NTSC/PAL, analog input (1) 0-5 VDC or 4-20 mA
- Digital output, capable of syncing 500mA.

PV450 Features and Operations

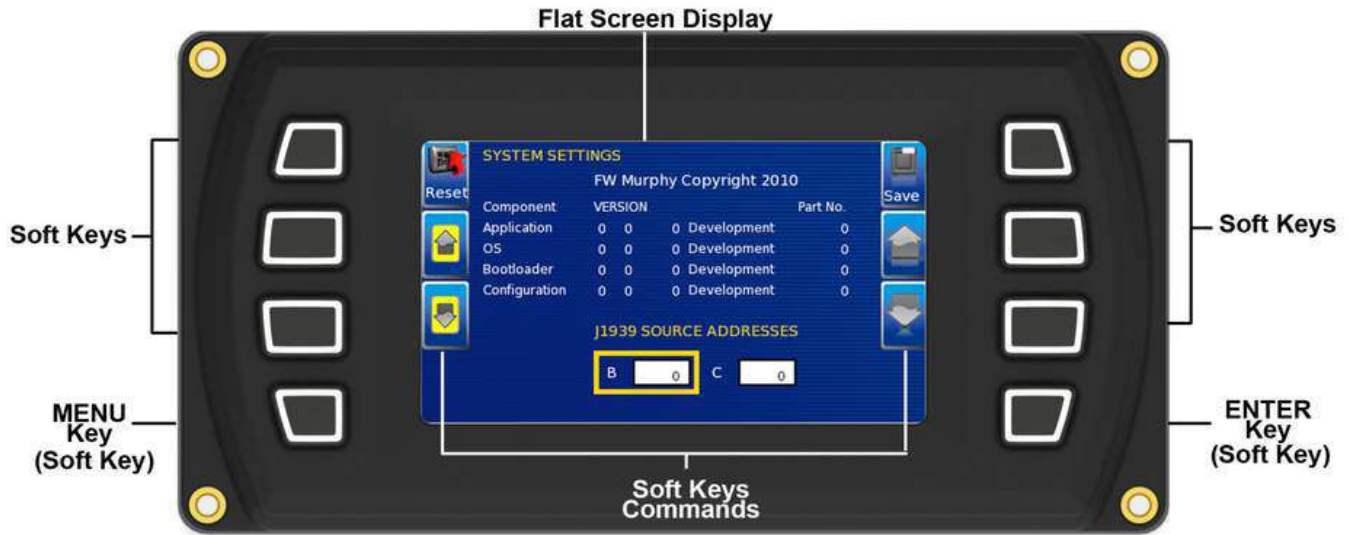

LCD Screen Display

A color screen displays gauges, soft key commands, and fault messages, as well as menu options for setup and configuration.

Soft Key Commands

Columns of vertical commands may be located to the left and/or right of the display. They will change according to the options available for the screen being displayed.

Soft Keys

The soft keys correspond to the soft key commands and allow selections to be made accordingly.

MENU Key

The bottom left key is a soft key reserved in most cases for the Menu. In rare cases, it could be used for other options. Pressing the **MENU** key at any time displays the list of menu options. If not labeled, it is the **MENU** key.

ENTER Key

The bottom right key is a soft key reserved in most cases for the Enter. In rare cases, it could be used for other options. Pressing the **ENTER** key will select the option displayed much like the **ENTER** key on a keyboard. If not labeled, it is the **ENTER** key.

Setting Up your PV450 Display for the First Time

The guidelines presented below are intended for setting up the PV450 display for the first time. Once the configuration is set up, there is no need to revisit or change any of the settings.

NOTE: If you require assistance during the set up process, contact FW Murphy customer support at +1(918) 317-4100.

1. At the main menu, press the soft key to the left of 'Utilities'.



2. The Utilities sub-menu is displayed.



3. From the 'Utilities' sub-menu, select 'System Settings'. The following screen is displayed.



4. With the cursor highlighting the J1939 source addresses, use the left side soft keys to scroll through the ports and the right side soft keys to change the address. Press the

Save key to save selected changes or the Restore Defaults key to return to the default settings.



Product Features

Power Up

There are two options to connecting the PV450 display:

- The battery and ignition inputs to display are both connect to the battery
- The battery input is connected to the battery and the ignition input is connected to the ignition switch.

NOTE: If both are connected to the battery, then an inline battery disconnect must be installed.

When the ignition is turned on, the PV450 display powers up and the engine health statistics can be viewed via preset gauges. To see more gauge screens, press the **Enter** key.

Main Menu

The main menu is activated at any time by pressing the **Menu** key on the display.



The following features are accessed through the main menu:

- **Gauge Display** – provides a series of screens that display engine and auxiliary information in a variety of formats.
- **Engine Diagnostics** – displays a list of engine fault codes and descriptions through a DM1 message structure.
- **User Settings** – allows you to customize the display options for ambient light and brightness, set US or metric units, language, specify the Home screen and screen setup status.
- **Utilities** – allows configuration of the plug address. Also displays software version information at the top of the page.

Gauge Display

The Gauge Display screen consists of several predefined layouts that contain combinations of analog gauges, straight bar gauges, or digital (text) readouts. These screens are displayed upon startup.

To scroll through the various gauge screens, press the **Prev** and **Next** soft keys. This can be repeated until all screens have been viewed. The currently displayed screen will stay active until another key is pressed.

Soft Key Commands

When a Gauge Display screen is active, pressing the **Enter** key will display soft key commands, as shown below. Continuing to press **Enter** will toggle through any additional soft keys, and will eventually remove the soft key commands from the screen.

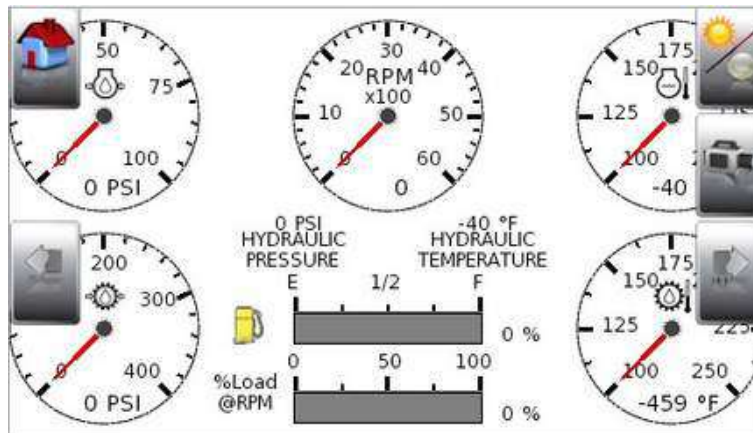

Soft Key commands provide quick navigation and access to the following features:

- Home
- Prev
- Day/Night
- Video (optional)
- Next

Home - This one-touch navigation feature allows a pre-defined Home screen to be accessed from the available Gauge Display screens. Once selected, the Home screen will be displayed anytime the **Home** key is pressed.

NOTE: For instructions on how to setup the Home screen, refer to the “**User Settings**” section of this manual.

Day/Night t Allows you to toggle the display screen between Day View and Night View.

NOTE: This feature can also be changed in the “User Settings” section of this manual.

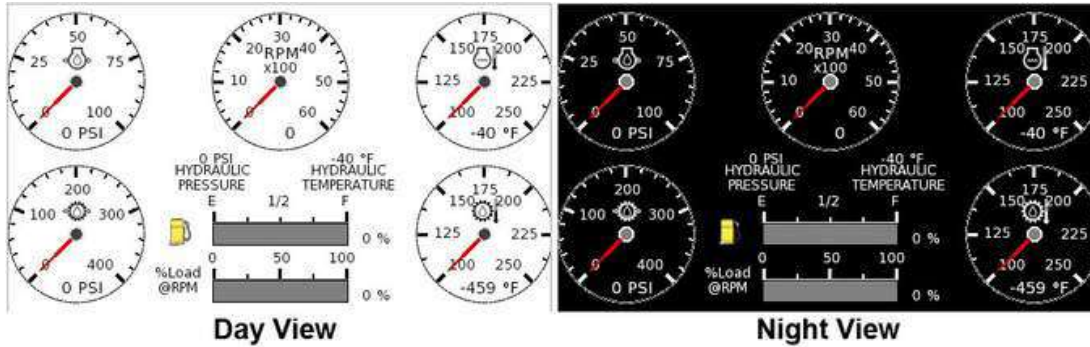

Video – When enabled, displays either full screen video or partial video within a window on the gauge display.

NOTE: For instructions on how to enable full or partial screen video, refer to the “User Settings” section of this manual.



Full View Video

NOTE: For instructions on how to turn screens ON or OFF, refer to the “User Settings” section of this manual.

Engine Diagnostics

Choosing Engine Diagnostics from the Menu, the display will query the engine(s) ECU and provide feedback on any diagnostic codes that have been activated and stored in the ECU for service needs.

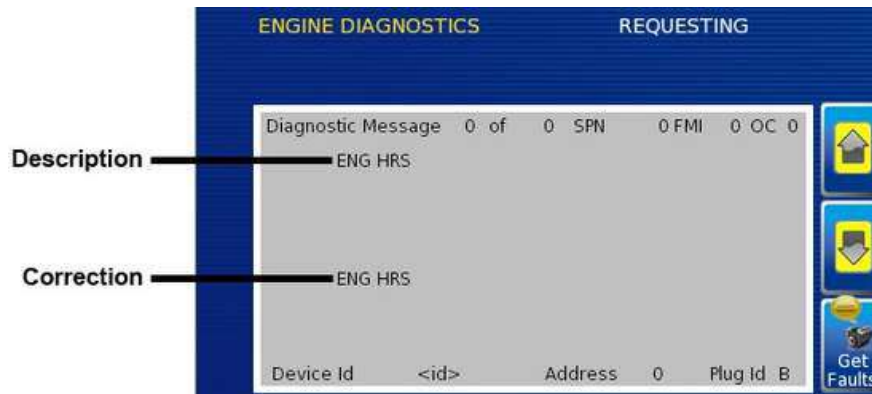

The Engine Diagnostics option displays faults based on engine or auxiliary source.

The following is a list of field definitions contained on the Engine Diagnostics screen:

- **Device ID** – identifies the component having the fault; engine 1, 2, or auxiliary.
- **Address** – identifies the address of the source of the fault (populates the Device ID).
- **Status** – indicates whether the fault has been corrected.
- **SPN** – "Suspect Parameter Number" - fault code
If not translated into text by the PV450 display, see the engine manufacturer's literature for the definition of the SPN number.
- **FMI** – "Failure Mode Indicator" - fault code
The FMI is defined by SAE J1939. If not translated into text, see the SAE standard, or the engine manufacturer's literature.
- **Occurrence Count (OC)** – The number of times the event has been flagged.
- **Description** – Most common SPN's and FMI's have text for the description stored in the PV450 display. If there is no text, then this SPN and FMI must be defined by referring to the engine manufacturer, or the SAE J1939 standard.
- **Correction** – Trouble-shooting guidelines for corrective action to take in addressing the fault.

NOTE: This field is only used with certain brands and models of engines.

Fault Code Popups

A fault condition will trigger a popup dialog box on the screen describing the nature of the fault. Corresponding red or amber fault lights on the corners of the unit are also activated to indicate the severity of the fault. The following screens are examples of warning and shutdown fault code popups.

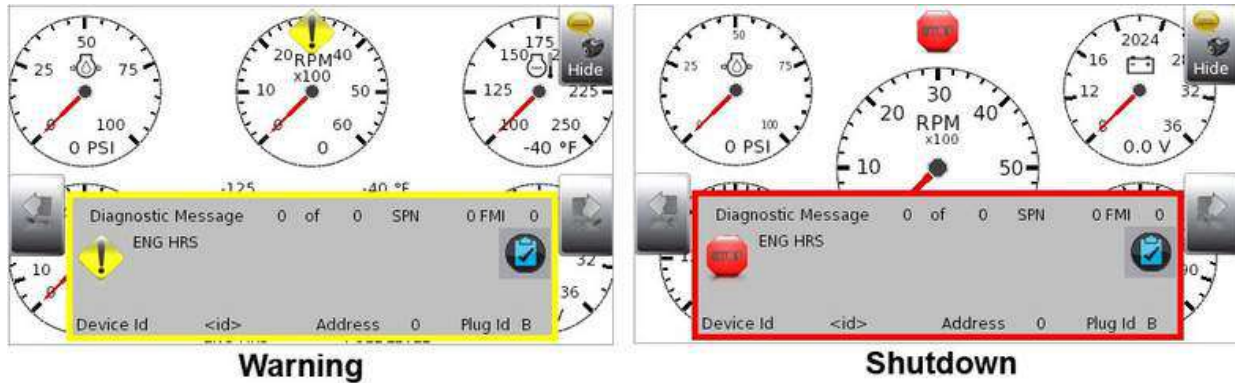

How to Hide/Show Faults

To hide the fault code popup being displayed on the screen, press the soft key on the right next to the “Hide” icon. The popup will disappear, however the “Warning” or “Stop” icon will remain on the screen to indicate there is still a fault. Pressing “Hide” does not clear the fault; it only hides the popup message.

When a fault code has been hidden, a “Recall” icon will remain on the right side. When this soft key is pressed, the fault code will again be displayed. When a popup message has been activated, a pop-up message will be displayed until the alarm is acknowledged by pressing the “Hide” key.

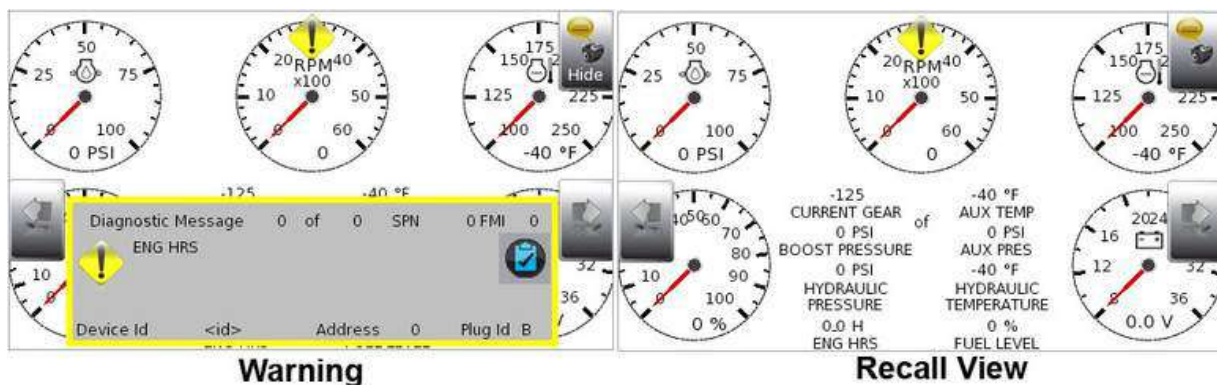

Scrolling Through Multiple Messages

The title-bar of the fault code popup may indicate multiple messages, as in ‘Diagnostic Message 1 of 3. Press the **Prev** and **Next** keys to scroll through the different messages.

User Settings

User Settings provides options to specify viewing preferences for the PV450 Display. Pressing yellow **Up** and **Down** arrows navigates through the options. To change an option, press the corresponding soft key button next to the desired soft key command.



Ambient Light

Night and Day options are provided for ambient lighting. The screens below illustrate these options. When the ambient lighting settings are changed in User Settings, the power-on default is changed.

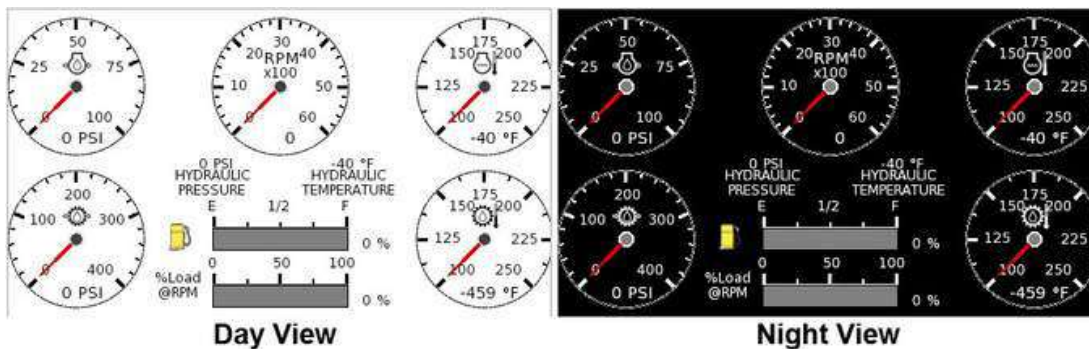

NOTE: The ambient lighting option is also accessible through soft key commands on the gauge display screens. When selected, the **Day/Night** soft key toggles the display to the opposite mode.

Brightness

You can set the brightness control by using the soft keys to change the settings in +5% increments until the desired brightness is achieved.

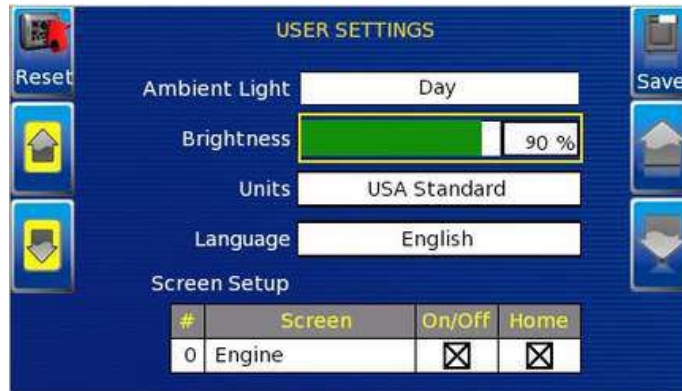

NOTE: Brightness level will change with ambient light setting. Two brightness levels are saved; one for day and one for night.

Units

Select how units are displayed by using the soft keys to select from the following:

- USA Standard
- Metric Bar
- Metric kPa
- British Standard

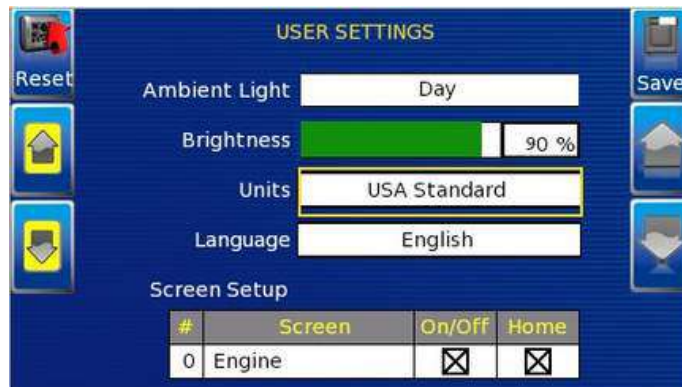

Language

This option allows you to select the language that will be displayed on the PV450. Available languages include English, French, Spanish, German, Italian, and Chinese. Languages are selected from the soft keys. Press the **Down** arrow to view additional languages. Additional languages include: Russian, Czech, Japanese, and Brazilian Portuguese.



Screen Setup

The Screen Setup option provides a list of screens that can be shown when accessing the Gauge Display screens.

Press the **Up** and **Down** arrow keys on the right to scroll through the screens.

Press the **Home** soft-key to select the screen as home.

NOTE: An X in the **On/Off** checkbox indicates the screen is on. A blank checkbox indicates the screen is turned off.

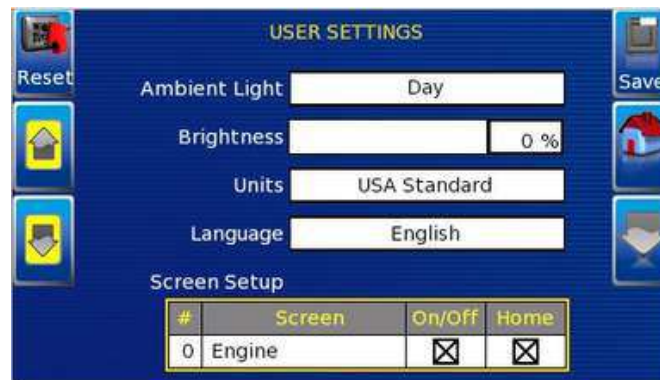

The Screen Setup screen also provides the user the ability to turn the screens ON or OFF by pressing the **Enable/Disable** soft key. If a screen is turned OFF, it will not show up when Gauge Display is activated.

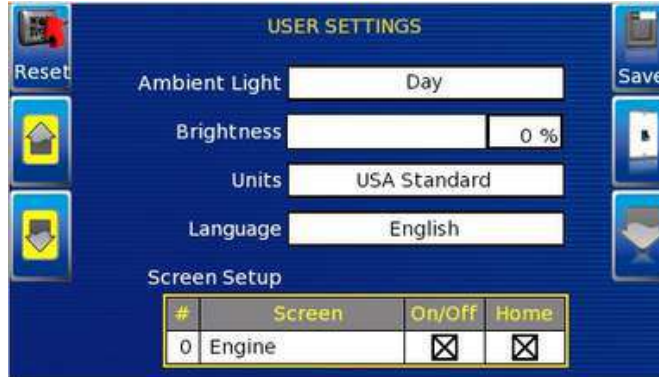

Home Screen

The Home Screen will be the first screen shown when Gauge Display is selected from the User Setting menu. The Home Screen is set to Engine by default and can be changed using the Screen Setup options on the User Settings screen.

Video (Optional)

By default, the Video screen is on or 'Enabled'. To 'Disable' video, change Video option to 'Off' in the screen setup dialog box using the Enable/Disable key in the top right corner. An updated image showing video screen highlighted / off will be displayed.

Save

Once all changes have been made, press **Save**. The following confirmation screen is displayed.

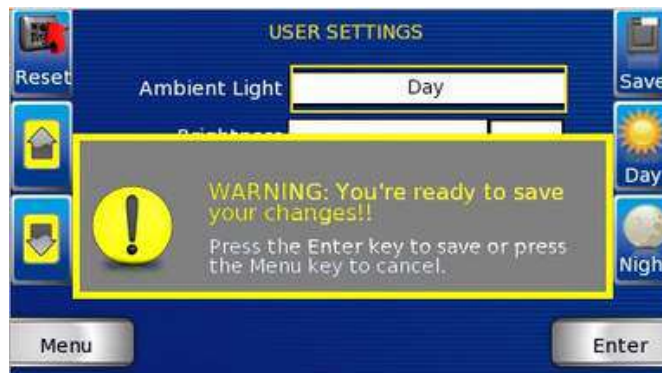

Restore Defaults

Restore Defaults sets the display to the original factory settings. During troubleshooting, this can be used as a last resort to completely reset the display to a known state.

To restore the default user settings, press **Restore Defaults**. The following confirmation screen is displayed.



Utilities

Utilities allow you to reset external gauges and configure communication settings. It is typically only accessed when the unit is first installed in order to configure the unit. The following sub-menu is displayed when Utilities is selected.



System Settings

The System Settings screen displays the current software version loaded on the PV450 display. You can set individual settings for the available options and “**Save**”, or choose to select “**Restore Defaults**” for the factory settings.

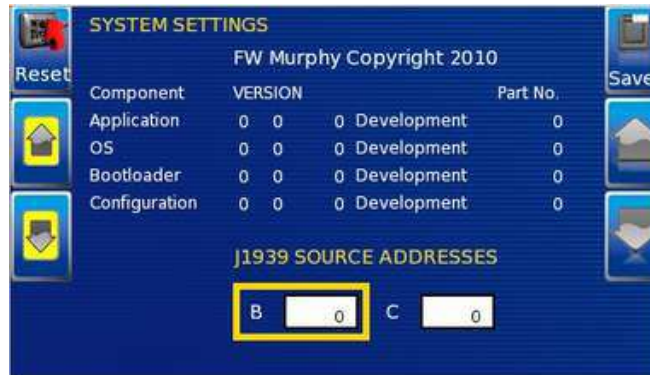

The yellow **Up** and **Down** keys on the left allow you to move the cursor through ‘J1939 Source Addresses’ fields. While the cursor is highlighting a field, the gray **Up** and **Down** keys scroll through available options. Once all the options have been selected, press **Save**.

Service Reminders

This option allows you to reset the 5 built-in service reminders:

- Change Engine Oil – Default interval 50.0 Hrs.
- Chang Air Filters – Default interval 75.0 Hrs.
- Change Hydraulic Oil – Default interval 100.0 Hrs.
- Service Engine – Default interval 125.0 Hrs.
- Service Machine – Default interval 150.0 Hrs.

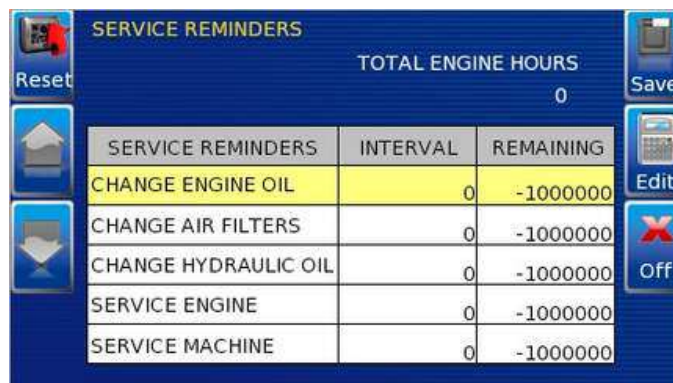

NOTE: The PV450 is Tier 4 compliant. If there are any questions on the Murphy Standard Configuration please contact Enovation Controls Technical Services at: (918) 317-1113

Specifications

Electrical

Display	Bonded 4.3" color transmissive TFT LCD WQVGA, 480 x 272
Resolution	pixels, 16-bit color 16:9 Landscape or portrait LED, 500-650
Aspect Ratio	cd/m2 (30,000 hr lifetime) Freescale iMX35, 32bit, 532 MHz
Orientation	QNX Real Time 256 MB (expandable to 8GB) 128 Mb DDR2
Backlighting	SDRAM 6 - 32 VDC, protected against reverse polarity and
Microprocessor	load-dump 10W Max Two CAN 2.0B; optional NMEA 2000
Operating System	isolation 1 MODBUS Master/Slave J1939, NMEA 2000,
Flash Memory	CANopen 4 Deutsch DT 6-pin connectors 8 tactile buttons USB
RAM	2.0 host (full speed), optional OTG support (1) Resistive, 0-5
Operating Voltage	V, or 4-20 mA (software configurable) Two NTSC/PAL input
Power Consumption	channels with one displayed at a time (1) open-drain, capable
CAN	of sinking 500mA With battery backup
RS-485	
Protocols	
Connection	
Keyboard	
USB	
Input	
Video Input (optional)	
Output	
Real-time Clock	
Environmental	

Operating Temperature

Storage Temperature

Protection -40° C to +85° C -40° C to +85° C IP67, front and back Electromagnetic Compatibility: 2004/108/EC J1113/2, 4, 11, 21, 26 and 41

Emissions and Immunity

- EN61000-6-4
- EN 61000-6-2 (immunity)
- EN 50121-3-2
- EN 12895
- EN 60945:2002

Vibration

Random vibration, 7.86 Grms (5-2000 Hz), 3 axis

Shock

+/- 50G in 3 axis

Mechanical

Case Material	Polycarbonate back case
---------------	-------------------------

Addendum

How to Install a Configuration from a USB Drive for the PV450

1. READ ALL INSTRUCTIONS BEFORE CONTINUING!
2. Power OFF the display unit.
3. Insert USB drive with the configuration file into USB port.
4. Press and hold the top left button (continue to hold).
5. Power ON the display while continuing to hold the button a few more seconds then release.
6. Use the keys next to up/down arrows to find the desired file.
7. Use the key next to the right arrow to select and continue. (The right arrow turns green, press again to confirm. Exit by pressing the key next to the red left arrow.)
8. When the installation is complete, a check mark is displayed in the middle of the screen.
9. The unit will reset itself automatically and boot to the new configuration.

PV450 CUTOUT

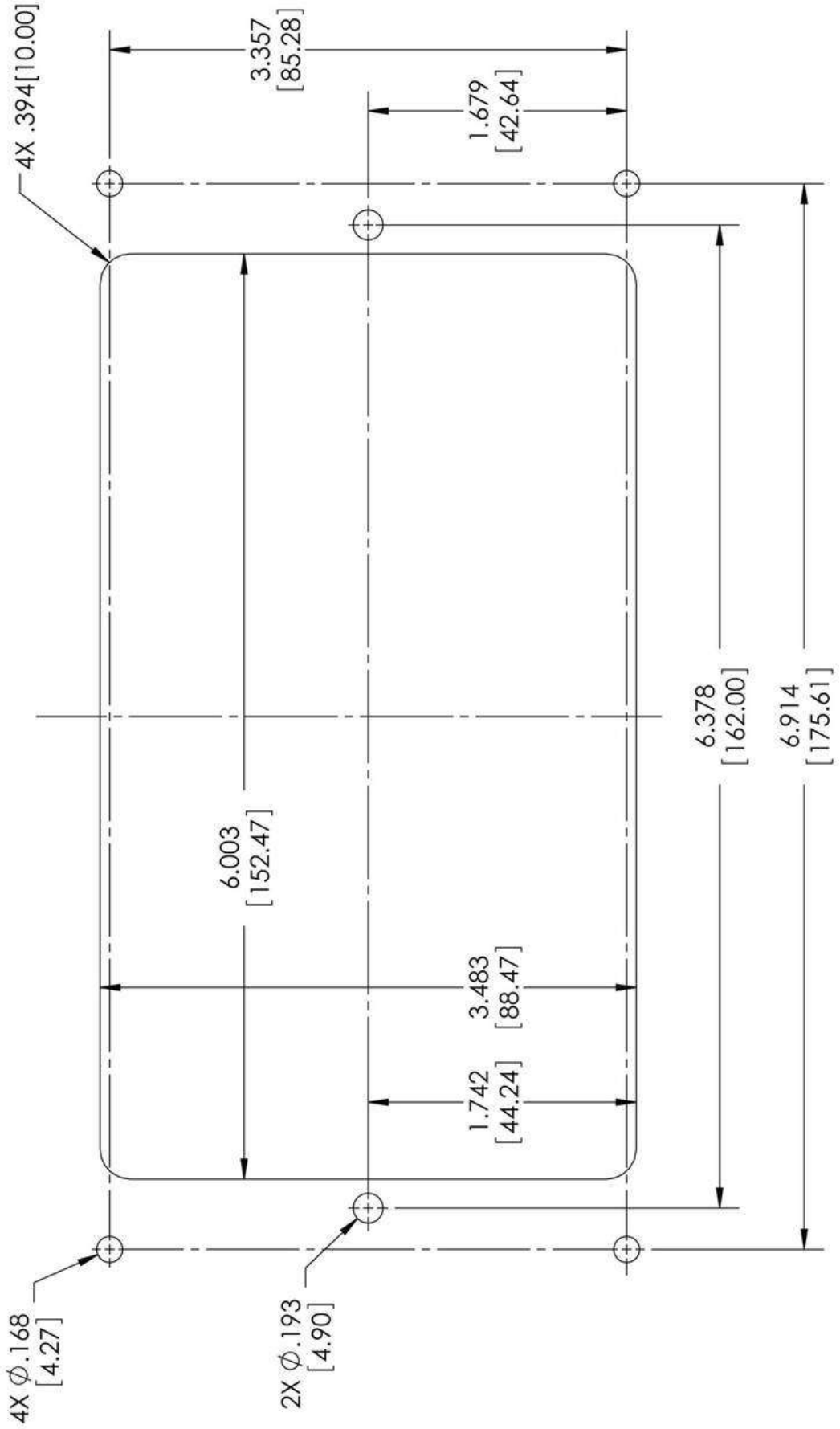

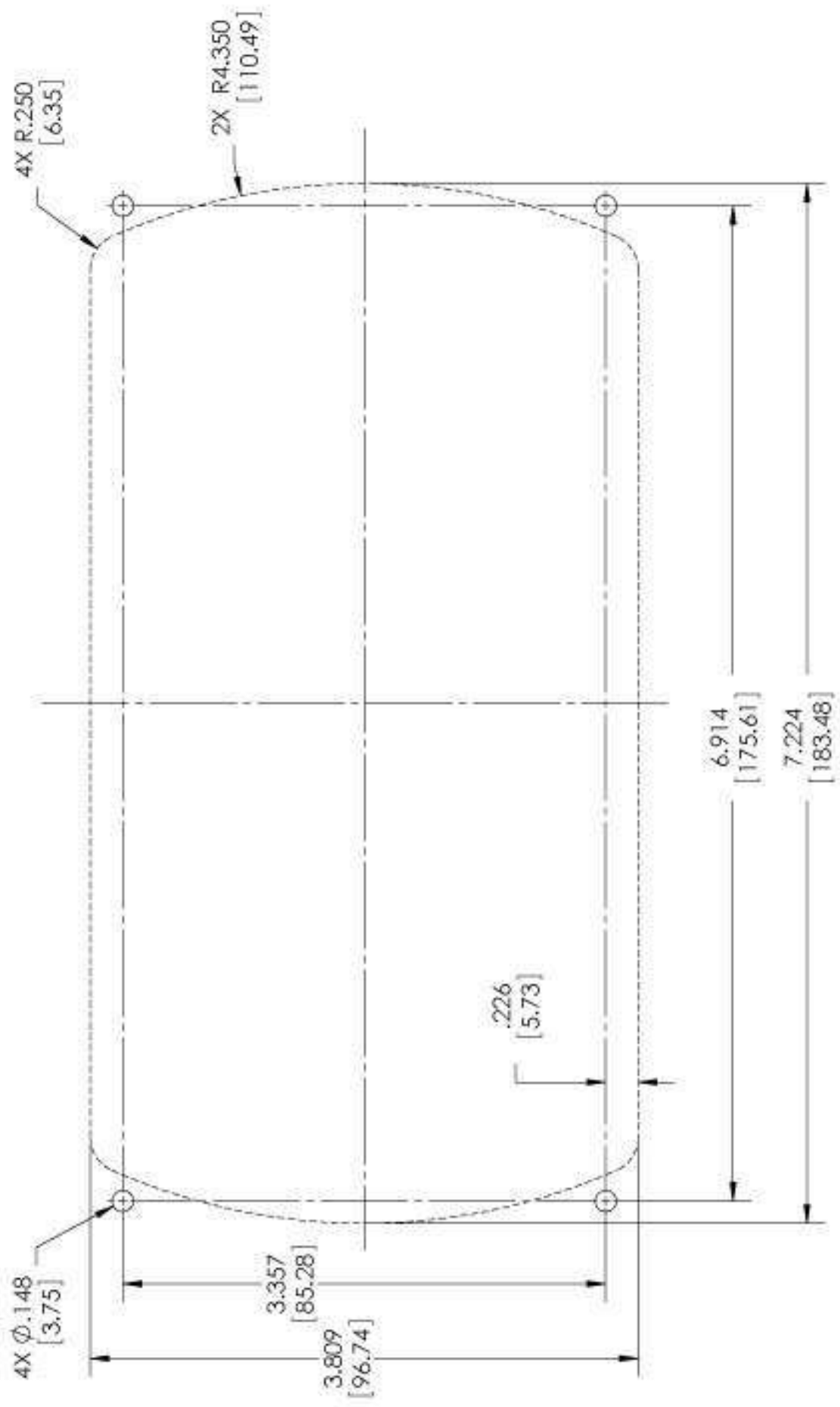

PV450 BACK MOUNT CUT-OUT 12-22-10 (SCALE: 1:1)

NOTES

In order to consistently bring you the highest quality, full-featured products, we reserve the right to change our specifications and designs at any time. MURPHY products and the Murphy logo are registered and/or common law trademarks of Enovation Controls, LLC. This document, including textual matter and illustrations, is copyright protected by Enovation Controls, LLC, with all rights reserved. (c) 2016 Enovation Controls, LLC. A copy of the warranty may be viewed or printed by going to www.fwmurphy.com/warranty.

ENOVIATION CONTROLS CORPORATE HEADQUARTERS

5311 S 122ND EAST AVENUE
TULSA, OK 74146

ENOVIATION CONTROLS – SAN ANTONIO OFFICE

5757 FARINON DRIVE
SAN ANTONIO, TX 78249

ENOVIATION CONTROLS – HOUSTON OFFICE

105 RANDON DYER RD
ROSENBERG, TX 77471

ENOVIATION CONTROLS LTD. – UNITED KINGDOM

CHURCH ROAD LAVERSTOCK
SALISBURY SP1 1OZ UK

MURPHY ENCONTROLS TECHNOLOGIES (HANGZHOU) CO, LTD.

77 23RD STREET
HANGZHOU ECONOMIC & TECHNOLOGICAL DEVELOPMENT AREA
HANGZHOU, ZHEJIANG 310018 CHINA

U.S. SALES & SUPPORT

ENCONTROLS PRODUCTS

PHONE: 210 495 9772
FAX: 210 495 9791
EMAIL: INFO@ENOVIATIONCONTROLS.COM
WWW.ENCONTROLS.COM

MURPHY PRODUCTS

PHONE: 918 317 4100
FAX: 918 317 4266
EMAIL: SALES@ENOVIATIONCONTROLS.COM
WWW.FWMURPHY.COM

MURPHY CONTROL SYSTEMS & SERVICES

PHONE: 281 633 4500
FAX: 281 633 4588
EMAIL: CSS-SOLUTIONS@ENOVIATIONCONTROLS.COM

MURPHY INDUSTRIAL PANEL DIVISION

PHONE: 918 317 4100
FAX: 918 317 4124
EMAIL: IPDSALES@ENOVIATIONCONTROLS.COM

INTERNATIONAL SALES & SUPPORT

UNITED KINGDOM

PHONE: +44 1722 410055
FAX: +44 1722 410088
EMAIL: SALES@ENOVIATIONCONTROLS.EU
WWW.FWMURPHY.EU

CHINA

PHONE: +86 21 6237 5885
FAX: +86 21 6237 5887
EMAIL: APSALES@ENOVIATIONCONTROLS.COM

LATIN AMERICA & CARIBBEAN

PHONE: 918 317 2500
EMAIL: LASALES@ENOVIATIONCONTROLS.COM

SOUTH KOREA

PHONE: +82 70 7951 4100
EMAIL: SKOREASALES@ENOVIATIONCONTROLS.COM

INDIA

PHONE: +91 91581 37633
EMAIL: INDIASALES@ENOVIATIONCONTROLS.COM



FH 28221 (Tulsa, OK - USA)
FH 620667 (San Antonio, TX - USA)
FH 28221 (Rosenberg, TX - USA)
FH 29422 (UK)



FH 523851 (China) TS 589322 (China)